



BID INVITATION

Pawtucket Housing Authority

St. Germain Manor Deck Improvements

**401 Mineral Spring Ave
Pawtucket, RI 02860**

September 1 ,2021

Prepared for:

Pawtucket Housing Authority
214 Roosevelt Avenue
Pawtucket, RI 02862



Prepared by:

Environmental Strategies & Management, Inc.
1005 Main Street, Suite #8120
Pawtucket, RI 02860
(401) 728-6860

ES&M Project No. 7180.22

DIVISION 00 – BIDDING AND CONTRACT REQUIREMENTS

*Pawtucket Housing Authority
St. Germain Manor Deck Improvements
Pawtucket, Rhode Island*

TABLE OF CONTENTS

DIVISION 00 – BIDDING AND CONTRACT REQUIREMENTS

Invitation to Bid
Information to Bidders
Bid Proposal Forms
Bid Bond Form
Proposed Subcontractors Form
Statement of Experience Form
Contract Agreement
Payment Bond
Performance Bond
Notice of Award
Notice to Proceed
Prevailing Wage Rates
HUD Documents
General Conditions
Special Conditions

DIVISION 01 – GENERAL REQUIREMENTS

01000	Summary of Work
01150	Measurements and Payments
01175	Temporary Facilities
01200	As-Built Drawings
01300	Submittals
01400	Quality Control
01600	Delivery Storage and Handling
066500	Plastic Simulated Wood Trim
077000	Vinyl Corrugated Sheeting

APPENDICES

Appendix A	Design Plans
Appendix B	Product Information

**Pawtucket Housing Authority
ADVERTISEMENT FOR BIDS
Galego Court Roof Replacement**

Sealed bids for the **Pawtucket Housing Authority, St. Germain Manor Deck Improvements Project** will be received at the Pawtucket Housing Authority (PHA) until **1:00 PM on September 24, 2021**. Each sealed bid needs to be marked on the outside of the envelope "Pawtucket Housing Authority, St. Germain Manor Deck Improvements Project". This project is subject to prevailing wage rates. Minority and women owned businesses are encouraged to submit bids.

The Pawtucket Housing Authority, St. Germain Manor Deck Improvements Project work encompassed under this Contract shall include, but not limited to, establishing a perimeter around specified work area, posting proper signage of possible hazards on site, wrapping existing posts with new trim, remove and reinstall existing rail system, remove and replace existing canopy trim, all as shown on the contract documents, and providing all materials, labor, tools and incidentals necessary to complete the work of this contract to the satisfaction of the Owner.

The Bidder must agree to commence work and fully complete the work of this Contract on the dates specified in the contract documents. The Bidder must agree also to pay liquidated damages for each consecutive calendar day thereafter as hereinafter provided in the Contract and General Conditions.

BID SECURITY in the form of bid bond, certified check, treasurer's check or cashier's check in the amount of 5(%) percent of the bid amount must accompany each Bid. No bidder may withdraw his Bid within 90 days after the actual date of the opening thereof.

Plans and Bid Documents are available on the website of the Pawtucket Housing Authority (pawthousing.org) under Bids/RFPs tab starting on **September 1, 2021**. It will be the Bidders responsibility to check the website for any addendum posted.

There will be a **non-mandatory** pre-bid conference on **September 8, 2021 at 10:00 AM** at the Project Site, 401 Mineral Springs Avenue, Pawtucket RI. Plans and Bid Documents are available.

Successful bidder must furnish 100% Performance Bond and 100% Labor and Material Payment Bond and the required insurance certificates and execute the Agreement within (10) calendar days following notification of the Acceptance of his/her Bid.

The Pawtucket Housing Authority reserves the right to reject any and all bids, to waive any technical or legal deficiencies, to accept individual bid items and excluding others, and to accept any a bid that it may deem to be in the best interest and most responsive of the Owner.

Attention of the bidders is particularly called to the requirements as to conditions of employment to be observed and minimum wage rates to be paid under the Contract. In conformity with the Provisions of Chapter 13 of Title 37, General Laws, Rhode Island, 1956, as amended, the minimum wages for a day's work paid to craftsmen, teamsters and laborers shall be not less than the customary and prevailing rate of wages for a day's work in the locality where the work is undertaken. Such a schedule of wages has been established on a minimum hourly basis and is on file in the office of the State Department of Labor.

All questions shall be submitted in writing via email to Roy Messier, Project Engineer of ES&M 401-728-6860, Ext. 212. email: rmessier@esm-inc.com by September 10, 2021 at 3:00 PM. Upon receipt of any

*Pawtucket Housing Authority
St. Germain Manor Deck Improvements
Pawtucket, Rhode Island*

Invitation to Bid - 1

written questions, an addendum will be issued to all bidders on September 14, 2021.

*Pawtucket Housing Authority
St. Germain Manor Deck Improvements
Pawtucket, Rhode Island*

Invitation to Bid - 2

INFORMATION TO BIDDERS

*Pawtucket Housing Authority
St. Germain Manor Deck Improvements
Pawtucket, Rhode Island*

Information to Bidders - 1

INFORMATION TO BIDDERS

1. RECEIPT AND OPENING OF BIDS
2. PREPARATION OF BID
3. TELEGRAPHIC MODIFICATION
4. CORRECTIONS
5. WITHDRAWAL OF BIDS
6. QUALIFICATIONS OF THE BIDDER
7. OBLIGATIONS OF THE BIDDER
8. CONDITIONS OF WORK
9. INFORMATION SUPPLIED TO BIDDERS
10. BID SECURITY
11. METHOD OF AWARD
12. EXECUTION OF THE AGREEMENT
13. LIQUIDATED DAMAGES FOR FAILURE TO ENTER INTO CONTRACT
14. NOTICE TO PROCEED
15. TIME OF COMPLETION AND LIQUIDATED DAMAGES
16. POWER OF ATTORNEY
17. ADDENDA AND INTERPRETATIONS
18. NOTICE OF SPECIAL CONDITIONS
19. LAWS AND REGULATIONS
20. MANUFACTURER'S EXPERIENCE
21. ACCESS TO SITE
22. SOIL BORINGS
23. RHODE ISLAND SALES AND USE TAX
24. JOB CONDITIONS
25. PRECONSTRUCTION CONFERENCE
26. LABOR REGULATIONS
27. PRE BID CONFERENCE

ARTICLE 1: RECEIPT AND OPENING OF BIDS

Sealed Bids for the work will be received and opened at the time and place indicated in the ADVERTISEMENT FOR BIDS.

Each Bid must be submitted in duplicate in a sealed envelope addressed to Pawtucket Housing Authority, 214 Roosevelt Avenue, Pawtucket RI 02860 and clearly labeled "**Pawtucket Housing Authority, St. Germain Manor Deck Improvements Project**" and bear the Title, Date and Time of Opening in the lower left corner. The envelope shall also bear the name and address of the Bidder.

If forwarded by mail, the sealed envelope containing the Bid must be enclosed in a second sealed envelope addressed to the Pawtucket Housing Authority, 214 Roosevelt Avenue, Pawtucket RI, 02860 and labeled "**Pawtucket Housing Authority, St. Germain Manor Deck Improvements Project**" as above. All bids forwarded by mail must be received in the office of PHA no later than 1:00 P.M. **September 24, 2021.**

The Owner may consider informal any bid not prepared and submitted in accordance with the provisions hereof and may waive any informality in or reject any and all bids. Conditional or qualified bids will not be accepted. Any bid received after the time and date specified shall not be considered. Should there be reasons why the Contract cannot be awarded within the specified period; the time may be extended by mutual agreement between the Owner and the bidder.

ARTICLE 2: PREPARATION OF BID

Each bid must be filled out on the prescribed forms. All blank spaces for bid prices must be filled in, in ink or typewritten, both in words and figures. All bids must be prepared in conformity with and shall be based on and submitted subject to all requirements of the Specifications and Drawings, together with all Addenda thereto. **All documents must be filled out and submitted with bid.** Incomplete bids will be rejected.

ARTICLE 3: TELEGRAPHIC MODIFICATION

Any bidder may modify his bid by telegraphic communication at any time prior to the scheduled closing time for receipt of bids, provided such telegraphic communication is received by the Owner prior to the closing time, and provided further, the Owner is satisfied that written confirmation of the telegraphic modification over the signature of the bidder was mailed and postmarked prior to the closing time.

The telegraphic communication should not reveal the bid price but should provide the addition or subtraction or other modifications so that the final prices or items will not be known by the Owner until the sealed bid is opened. If written confirmation is not received prior to the bid closing time, no consideration will be given to the telegraphic modification.

ARTICLE 4: CORRECTIONS

Erasures or other changes in the bid must be explained or noted over the signature of the bidder.

ARTICLE 5: WITHDRAWAL OF BIDS

Bids may be withdrawn only on written request dispatched by the bidder in time for delivery in
*Pawtucket Housing Authority
St. Germain Manor Deck Improvements
Pawtucket, Rhode Island*

the normal course of business prior to the time fixed for the opening, provided that written confirmation of any withdrawal over the signature of the bidder is placed in the mail and postmarked prior to the time set for the opening of the bids. Negligence on the part of the bidder in preparing his bid confers no right of withdrawal or modification of his bid after such bid has been opened. No bidder may withdraw his bid within ninety (90) days after the actual date of the opening thereof.

ARTICLE 6: QUALIFICATIONS OF THE BIDDER

The Owner may make such investigations as he deems necessary to determine the ability of the bidder to perform the work, and the bidder shall furnish to the Owner all such information and data for this purpose as the Owner may request. The Owner reserves the right to reject any bid if the evidence submitted by, or investigation of, such bidder fails to satisfy the Owner that such bidder is properly qualified to carry out the obligations of the Contract and to complete the work contemplated therein.

ARTICLE 7: OBLIGATIONS OF THE BIDDER

Bidders must satisfy themselves by personal examination at the site of the proposed work, by review of the Drawings and the Specifications including Addenda, and by such other means as they may prefer, as to the actual conditions, requirements, and limits of the proposed work, and as to the accuracy of the information and statements herein contained. The submission of any bid will be accepted by the Owner as satisfactory proof that the bidder has satisfied himself in these respects. The bidder shall not at any time after the submission of a bid dispute or complain of such statements or information, nor assert that there was any misunderstanding in regard to the nature, or amount of work to be done. The failure or omission of any bidder to examine any form, instrument or document shall in no way relieve the bidder of his obligation to furnish all materials and labor necessary to carry out the provisions of the Contract Documents and to complete the contemplated work for the considerations set forth in his bid, if his bid is accepted.

ARTICLE 8: CONDITIONS OF WORK

Insofar as possible, the Contractor, in carrying out his work, must employ such methods or means as will not cause any interruption of or interference with traffic, with the use of existing facilities and utilities, with the use of municipally or State or privately owned lands, or with the work being performed by others. The Contractor must satisfy himself by his own investigation and research as to the nature and location of the work, the general and local conditions, including, but not restricted to, those bearing upon the transportation, disposal, handling and storage of materials, water, electric power, roads, means of access, the construction and making of connections of the work to existing facilities and utilities, or other similar conditions at the site, the character of equipment and facilities needed preliminary to and during the prosecution of the work, requirements of owners and controlling authorities having jurisdiction over the various lands, existing structures, facilities and utilities, and all other conditions affecting the work to be done and labor and materials needed.

ARTICLE 9: INFORMATION SUPPLIED TO BIDDERS

The Owner shall provide to bidders prior to bidding all information that is pertinent to, and delineates and describes, the land owned and rights-of-way acquired or to be acquired.

*Pawtucket Housing Authority
St. Germain Manor Deck Improvements
Pawtucket, Rhode Island*

The Contract Documents contain the provisions required for the construction of the project. Information obtained from any officer, agent, or employee of the Owner or any other person shall not affect the risks or obligations assumed by the contractor or relieve him from fulfilling any of the conditions of the Contract. Any information given relating to subsurface and other conditions, natural phenomena, existing pipes and other structures is from the best sources available to the owner. All such information is furnished for the information and convenience of bidders and is not guaranteed.

ARTICLE 10: BID SECURITY

Each bid must be accompanied by a certified check of bidder, or a bid bond prepared on the form of bid bond attached hereto, duly executed by the bidder as principal and having as surety thereon a surety company approved by the Owner, in the amount of (5) Five (%) percent of the bid. Such checks or bid bonds will be returned to all but the selected bidder within three days after the Owner and the accepted bidder have executed the contract; or if no award has been made within 90 days after the date of the opening of the bids, upon demand of the bidder at any time thereafter, so long as he has not been notified of the acceptance of his bid. The check or bid bond of the successful bidder will be retained until the payment bond and performance bond have been executed and approved, after which it will be returned.

ARTICLE 11: METHOD OF AWARD

This contract will be awarded based on the lowest qualified bid, experience of the bidder, and most responsive bid that reflects the best product received by Pawtucket Housing Authority.

ARTICLE 12: EXECUTION OF THE AGREEMENT

A contract in the form set forth hereinafter will be required to be executed by the successful bidder and the Owner. The attention of all bidders, therefore, is called to the form of the Agreement and the provisions thereof. The party to whom the Contract is awarded will be required to obtain the performance bond and payment bond within ten (10) calendar days from the date when the Notice of Award is delivered to the bidder. The Notice of Award shall be accompanied by the necessary Agreement and bond forms. The Contractor shall furnish a performance bond and a payment bond, each in the amount of 100 percent of the Contract Price, with a corporate surety approved by the Owner, as security for faithful performance of Contract.

ARTICLE 13: LIQUIDATED DAMAGES FOR FAILURE TO ENTER INTO CONTRACT

The successful bidder, upon his failure or refusal to execute and deliver the Contract and bonds required within 10 days after he has received notice of the acceptance of his bid, shall forfeit to the Owner, as liquidated damages for such failure or refusal, the surety deposited with his bid.

ARTICLE 14: NOTICE TO PROCEED

The Notice to Proceed shall be issued within ten (10) days of the execution of the Agreement by the Owner. Should there be reasons why the Notice to Proceed cannot be issued within such period; the time may be extended by mutual agreement between the Owner and Contractor. If the Notice to Proceed

*Pawtucket Housing Authority
St. Germain Manor Deck Improvements
Pawtucket, Rhode Island*

has not been issued within the ten (10) day period or within the period mutually agreed upon, the Contractor may terminate the Agreement without further liability on the part of either party.

ARTICLE 15: TIME OF COMPLETION AND LIQUIDATED DAMAGES

The bidder must agree to commence construction work on the date specified in the written Notice to Proceed of the Owner and to fully complete the Project within **thirty (30) calendar days**. The Owner reserves the right to stop all work due to severe weather conditions, or other such conditions that may in his/her opinion interfere with the normal operation of the site and/or the safety of its occupants. The bidder must agree also to pay as liquidated damages, the sum of \$300.00 for each consecutive calendar day thereafter as hereinafter provided in the Contract and General Conditions.

ARTICLE 16: POWER OF ATTORNEY

Attorney-in-fact who sign bid bonds or contract bonds must file with each bond a certified and effectively dated copy of their power of attorney.

ARTICLE 17: ADDENDA AND INTERPRETATIONS

No interpretation of the meaning of the Drawings, Specifications, or other pre-bid documents will be made to any bidder orally. Every request for such interpretation should be in writing, addressed to Environmental Strategies & Management, Inc., 1005 Main Street, Suite #8120, Pawtucket, RI 02860; or via email to Roy Messier with Environmental Strategies & Management, Inc. (rmessier@esm-inc.com).

In order to be given consideration, such request must be made at least five- (5) workdays prior to the date fixed for the opening of bids. Any and all interpretations and any supplemental instructions will be in the form of written Addenda to the Specifications, which, if issued, will be transmitted electronically by email with return receipt requested to all prospective bidders, not later than three work days prior to the date fixed for the opening of bids. Failure of any bidder to receive any such addenda or interpretations shall not relieve the bidder from any obligation under his bid as submitted. All Addenda so issued shall become a part of the Contract Documents.

ARTICLE 18: NOTICE OF SPECIAL CONDITIONS

Attention is particularly called to those parts of the Contract Documents and Specifications that deal with the following:

- A. inspection and testing of materials
- B. insurance requirements
- C. wage rates
- D. interpretation of Drawings and Specifications

ARTICLE 19: LAWS AND REGULATIONS

The bidder's attention is directed to the fact that all applicable State laws, municipal ordinances and rules, and regulations of all authorities having jurisdiction over construction of the project shall apply to the Contract the same as though herein written in full.

*Pawtucket Housing Authority
St. Germain Manor Deck Improvements
Pawtucket, Rhode Island*

ARTICLE 20: MANUFACTURER'S EXPERIENCE

Wherever it may be written that an equipment manufacturer must have a specified period of experience with his product, equipment which does not meet the specified experience period may, at the option of the Owner, be considered if the equipment supplier of manufacturer is willing to provide a bond or cash deposit for the duration of the specified time period which will guarantee replacement of that equipment in the event of failure.

ARTICLE 21: ACCESS TO SITE

Representatives of the "OWNER" shall have access to the work wherever it is in preparation or progress and the Contractor shall provide proper facilities for such access and inspection.

ARTICLE 22: SOIL BORINGS

No Soil Borings for this Project

ARTICLE 23: RHODE ISLAND SALES AND USE TAX

Materials and equipment purchased for installation under this Contract are exempt from the Rhode Island Sales Tax. The exemption from the Sales Tax shall be taken into account by the Contractor during bidding.

ARTICLE 24: JOB CONDITIONS

The bidder is advised that free vehicular and pedestrian access must be maintained to the site at all times. The method of construction must be therefore compatible with this requirement of free access.

ARTICLE 25: PRECONSTRUCTION CONFERENCE

The Contractor shall be prepared to attend a pre-construction conference scheduled by the Owner after award of the Contract, but prior to the actual commencement of work at the site. The main item of discussion will be the Contractor's construction schedule, the proposed Superintendent, and access for residents.

ARTICLE 26: LABOR REGULATIONS

The following paragraphs regarding nondiscrimination in employment shall be included and become part of these Specifications:

- A. The Contract for work under this proposal will obligate the Contractor and Subcontractors not to discriminate in employment practices and conform to Executive Order No. 11246. The Contractor shall also comply with the Labor Standards Provisions for minimum wages and payroll certification.

*Pawtucket Housing Authority
St. Germain Manor Deck Improvements
Pawtucket, Rhode Island*

- B. Bidders must, if required, submit a compliance report concerning their employment practices and policies in order to maintain their eligibility to receive award of the Contract.
- C. Successful bidders must, if required, submit a list of all Subcontractors who will perform work on the project, and written signed statements from authorized agents of labor pools with which they will or may deal with for employees on the work, together with any information to the effect that such labor pools practices or policies are in conformity with Executive Order No. 11246; that they will affirmatively cooperate in or offer no hindrance to the recruitment, employment, and equal treatment of employment, and equal treatment of employees seeking employment and performing work under this Contract; or a certification as to when such agents or labor pools have failed or refused to furnish them, prior to award of the Contract.
- D. Contractor shall be required to submit certified payroll documentation when request to certify that wages are in compliance with the current wage rate determination.

ARTICLE 27: PRE BID CONFERENCE

There will be a **non-mandatory** pre-bid conference on **September 8, 2021 at 10:00 AM**, at the Project Site, located at 401 Mineral Spring Ave, Pawtucket Rhode Island.

END OF INFORMATION TO BIDDERS

BID PROPOSAL

*Pawtucket Housing Authority
St. Germain Manor Deck Improvements
Pawtucket, Rhode Island*

Bid Proposal - 1

BID PROPOSAL

Proposal of _____ (hereinafter "Bidder"), organized and existing under the laws of the State of _____ doing business as _____ * to Pawtucket Housing Authority (hereinafter called "OWNER"):

In compliance with our Advertisement for Bids, BIDDER hereby proposes to perform all work for the Pawtucket Housing Authority, St. Germain Manor Deck Improvements Project in strict accordance with the CONTRACT DOCUMENTS, within the time set forth therein, and at the prices stated below.

By submission of this BID, each BIDDER certifies, and in the case of a joint BID each party thereto certifies as to his own organization, that his BID has been arrived at independently, without consultation, communication, or agreement as to any matter relating to this BID with any other BIDDER or with any competitor.

BIDDER hereby agrees to commence WORK under this Contract within 10 days of issue of a Purchase Order and Notice to Proceed. The contractor shall provide estimated days required to complete the project.

BIDDER acknowledges receipt of the following ADDENDA:

ADDENDUM _____ DATED:

ADDENDUM _____ DATED:

ADDENDUM _____ DATED:

* Insert "a corporation", "a partnership", or "an individual" as applicable.

NOTE, THE BID PROPOSAL DOCUMENTS INCLUDE THE BID PROPOSAL FORM, BID FORM, LISTING OF PROPOSED SUBCONTRACTORS, AND STATEMENT OF CONTRACTORS EXPERIENCE

*Pawtucket Housing Authority
St. Germain Manor Deck Improvements
Pawtucket, Rhode Island*

BID FORM

Note: The Price for each item must be written in words and figures

ITEM NO.	DESCRIPTION	ITEM QUANTITY	UNIT MEASURE	UNIT BID PRICE (\$0.00)	AMOUNT (QxP) (\$0.00)
-----------------	--------------------	----------------------	---------------------	--------------------------------	------------------------------

1.	Deck Improvements	56	EA	\$ _____	\$ _____
----	-------------------	----	----	----------	----------

Total Amount in words: \$ _____

TOTAL \$ _____

Words: _____

ALTERNATE BID ITEMS

ITEM NO.	DESCRIPTION	ITEM QUANTITY	UNIT MEASURE	UNIT BID PRICE (\$0.00)	AMOUNT (QxP) (\$0.00)
-----------------	--------------------	----------------------	---------------------	--------------------------------	------------------------------

1.	Wrap 6"x6" Post	1	EA	\$ _____	\$ _____
----	-----------------	---	----	----------	----------

Total Amount in words: \$ _____

Bidder understands that the Owner reserves the right to reject any or all bids and to waive informalities in the bidding.

The Bidder agrees that this bid shall be good and may not be withdrawn for a period of 90 Calendar Days after the scheduled closing time for receiving bids.

Upon receipt of written notice of the acceptance of this Bid, Bidder will execute the formal contract attached within 10 days.

The undersigned declares; that the only person interested in this Proposal as principals are named herein as such; that no official of the Owner and no person acting for or employed by the Owner is interested directly or

*Pawtucket Housing Authority
St. Germain Manor Deck Improvements
Pawtucket, Rhode Island*

indirectly in this Proposal, or in any contract which may be made under it, or in any expected profits to arise there from; that this Proposal is made in good faith, without fraud, collusion or connection with any other person bidding or refraining from bidding for the same work; that he has examined carefully the said instructions and all other documents bound herewith, and the Contract Drawings relating to the contract covered by this Proposal and hereby makes them part of this Proposal; that he has informed himself fully in regard to all conditions pertaining to the work and place where it is to be done; and that he has made his own examination and carefully checked his estimates of cost and from them makes this Proposal.

The Owner reserves the right to accept individual bid items or combinations thereof.

In compliance with the requirements of Rhode Island General Law, Section 5-65-23, my Rhode Island license number for the work to be performed by this firm as prime contractor is:

License No. _____

(Signature of authorized representative)

(Title of authorized representative)

(Seal if bid is by a corporation)

(Business Address)

END OF DOCUMENT

BID BOND FORM

*Pawtucket Housing Authority
St. Germain Manor Deck Improvements
Pawtucket, Rhode Island*

Bid Bond - 1

BID BOND

KNOW ALL MEN BY THESE PRESENTS, that we, the undersigned _____, as Principal, and _____, as Surety, are hereby held and firmly bound unto Pawtucket Housing Authority, as OWNER in the penal sum of _____ (\$ _____), for the payment of which, well and truly to be made, we hereby jointly and severally bind ourselves, successors and assigns.

Signed, this _____ day of _____ 20__.

The condition of the above obligation is such that whereas the Principal has submitted to Pawtucket Housing Authority attached hereto and hereby made a part hereof to enter into a Contract in writing, for the **PAWTUCKET HOUSING AUTHORITY ST. GERMAIN MANOR DECK IMPROVEMENTS**.

NOW, THEREFORE,

- (a) If said BID shall be rejected, or
- (b) If said BID shall be accepted and the Principal shall execute and deliver a Contract in the Form of Contract attached hereto (properly completed in accordance with said BID) and shall furnish a BOND for his faithful performance of said Contract, and for the payment of all persons performing labor or furnishing materials in connection therewith, and shall in all other respects perform the Agreement created by the acceptance of said BID.

Then this obligation shall be void, otherwise the same shall remain in force and effect; it being expressly understood and agreed that the liability of the Surety for any and all claims hereunder shall, in no event, exceed the penal amount of this obligation as herein stated.

The Surety, for value received, hereby stipulates and agrees that the obligations of said Surety and its BOND shall be in no way impaired or affected by any extension of the time with which the OWNER may

*Pawtucket Housing Authority
St. Germain Manor Deck Improvements
Pawtucket, Rhode Island*

accept such BID; and said Surety does hereby waive notice of any such extension.

IN WITNESS WHEREOF, the Principal and the Surety have hereunto set their hands and seals, and such of them as are corporations have caused their corporate seals to be hereto affixed and these presents to be signed by their proper officers, the day and year first set forth above.

Notary

_____ and
Principal

Seal

Surety

IMPORTANT: - Surety companies executing BONDS must appear on the Treasury Department's most current list (Circular 570 as amended) and be authorized to transact business in the State where the project is located.

*Pawtucket Housing Authority
St. Germain Manor Deck Improvements
Pawtucket, Rhode Island*

PROPOSED SUBCONTRACTORS FORM

*Pawtucket Housing Authority
St. Germain Manor Deck Improvements
Pawtucket, Rhode Island*

Subcontractors -1

THE BIDDER SHALL STATE THE NAMES OF SUBCONTRACTORS
THAT HE PROPOSES TO USE
PROPOSED SUBCONTRACTORS

If none, write "None"

* Description of Work

Proposed Subcontractor, Name

Address

* Description of Work

Proposed Subcontractor, Name

Address

* Description of Work

Proposed Subcontractor, Name

Address

* Description of Work

Proposed Subcontractor, Name

Address

*Insert description of work and subcontractors' names as may be required.

This is to certify that all names of the above-mentioned subcontractors are submitted with full knowledge and consent of the respective parties.

The Bidder warrants that none of the proposed subcontractors have any conflict of interest as respects this Contract.

BIDDER

(FILL IN NAME)

BY

(Signature & Title)

*Pawtucket Housing Authority
St. Germain Manor Deck Improvements
Pawtucket, Rhode Island*

STATEMENT OF EXPERIENCE FORM

*Pawtucket Housing Authority
St. Germain Manor Deck Improvements
Pawtucket, Rhode Island*

Experience - 1

STATEMENT OF CONTRACTOR'S EXPERIENCE

The following experience sheet shall be completed by each Bidder, any bid submitted without a fully completed Experience sheet will be rejected by the Owner.

1. Have you ever failed to complete any work awarded to you?
If so, state where and why.

2. What similar projects has your organization completed within the last 5 years?

Class of Work	Contract Amount	When Completed	Name & Address of Engineer or Owner
(1)	(2)	(3)	(4)

*Pawtucket Housing Authority
St. Germain Manor Deck Improvements
Pawtucket, Rhode Island*

CONTRACT AGREEMENT

*Pawtucket Housing Authority
St. Germain Manor Deck Improvements
Pawtucket, Rhode Island*

Agreement - 1

AGREEMENT

THIS AGREEMENT, made this _____ day of _____, 2021 by and between The Pawtucket Housing Authority, hereinafter called "OWNER" and _____ doing business as (an individual), or (a partnership), or (a corporation) hereinafter called "CONTRACTOR."

WITNESS TO: that for and in consideration of the payments and agreements hereinafter mentioned;

1. The CONTRACTOR will commence and complete the **Pawtucket Housing Authority St. Germain Manor Deck Improvements Project**.
2. The CONTRACTOR will furnish all of the material, supplies, tools, equipment, labor and other services necessary for the construction and completion of the PROJECT described herein.
3. The CONTRACTOR will commence the work required by the CONTRACT DOCUMENTS within 10 calendar days after the date of the NOTICE TO PROCEED and will complete the project within 30 calendar days unless the dates for completion are extended otherwise by the CONTRACT DOCUMENTS or scope of work is redefined by the Owner.
4. The CONTRACTOR agrees to perform all the WORK described in the CONTRACT DOCUMENTS and comply with the terms therein for the amount of \$ _____ as shown in the Bid Schedule.
5. The term "CONTRACT DOCUMENTS" means and includes the following:
 - A. REQUEST FOR BIDS
 - B. INFORMATION TO BIDDERS
 - C. BID PROPOSAL
 - D. FORM OF BID BONDS
 - E. PROPOSED SUBCONTRACTORS
 - F. STATEMENT OF EXPERIENCE
 - G. CONTRACT AGREEMENT
 - H. FORM OF PAYMENT BOND
 - I. FORM OF PERFORMANCE BOND
 - K. NOTICE OF AWARD
 - L. NOTICE TO PROCEED
 - GC GENERAL CONDITIONS
 - SC SPECIAL CONDITIONS
 - PW PREVAILING WAGE SHEET
 - HD HUD DOCUMENTS CONTAINED IN BID SPECIFICATIONS

Drawings and Technical Specifications prepared or issued by Environmental Strategies & Management, Inc. dated August 2021.

Addenda:

No.	Dated	2021
No.	Dated	2021

6. The OWNER will pay the CONTRACTOR in the manner and at such times as set forth in the General Conditions such amounts as required by the Contract Documents.
7. Retention from progress payments will be in accordance with the requirements stipulated in the General Conditions.

*Pawtucket Housing Authority
St. Germain Manor Deck Improvements
Pawtucket, Rhode Island*

Agreement - 2

8. This Agreement shall be binding upon all parties hereto and their respective heirs, executors, administrators, successors and assigns.

IN WITNESS WHEREOF, the parties hereto have executed, or caused to be executed by their duly authorized officials, this Agreement in (Quadruplicate copies) each which shall be deemed an original on the date first above written.

OWNER: _____

BY: _____

NAME:

TITLE:

(SEAL)
WITNESS: _____

NAME: _____

TITLE: _____

CONTRACTOR: _____

BY: _____

NAME: _____

ADDRESS: _____

(SEAL)
WITNESS: _____

NAME: _____

TITLE: _____

PAYMENT BOND

*Pawtucket Housing Authority
St. Germain Manor Deck Improvements
Pawtucket, Rhode Island*

Bonds -1

LABOR AND MATERIAL PAYMENT BOND

KNOW ALL MEN BY THESE PRESENTS, that _____ (Name of Contractor)
of

(Address of Contractor)

as Principal hereinafter called Principal, and _____ of

(Name of Surety)

(Address of Surety)

_____, a Corporation, organized and existing under the laws of the State of _____, as Surety, hereinafter called Surety, are held and firmly bound unto Pawtucket Housing Authority, as Oblige, hereinafter called the Oblige, in the full penal sum of _____ dollars (\$ _____) in lawful money of the United States for the payment whereof Principal and Surety bind themselves, their heirs, executors, administrators, successors and assigns, jointly and severally, firmly by these presents.

THE CONDITION OF THIS OBLIGATION IS SUCH THAT WHEREAS said Principal has entered into a certain written contract with said Oblige, dated the _____ day of _____, 20____, which written contract provides for the **PAWTUCKET HOUSING AUTHORITY ST. GERMAIN MANOR DECK IMPROVEMENTS** project which contract, together with all plans and specifications now made or which may hereafter be made in extension, modification of alteration thereof, are hereby referred to, incorporated in and made a part of this bond as though herein fully set forth.

NOW, THEREFORE, if the Principal shall promptly make payment to all persons, firms, subcontractors, and corporations furnishing materials for or performing labor in the prosecution of the work provided for in such contract, and any authorized extension or modification thereof, including all amounts due for materials, lubricants, oil, gasoline, coal and coke, repairs or machinery, equipment and tools, consumed or used in connection with the construction of such work, and all insurance premiums on said work and for all labor, performed in such work whether by subcontractor or otherwise, then this obligation shall be void; otherwise to remain in full force and effect.

PROVIDED, HOWEVER, that this bond is executed, pursuant to the provision of the General Statutes of the State of Rhode Island and the rights and liabilities hereunder shall be determined and limited by said sections to the same extent as if they were copies at length herein.

PROVIDED, FURTHER, that the said Surety for value received hereby stipulates and agrees that no change, extension of time, alteration or addition to the terms of the contract or to the work to be performed thereunder or the specifications accompanying the same shall in any wise affect its obligation on this bond, and it does hereby waive notice of any such change, extension of time, alteration or addition to the terms of the contract or to the work or to the specifications.

PROVIDED, FURTHER, that no final settlement between the Oblige and the Contractor shall abridge the right of any beneficiary hereunder, whose claim may be unsatisfied.

*Pawtucket Housing Authority
St. Germain Manor Deck Improvements
Pawtucket, Rhode Island*

IN WITNESS WHEREOF, the said principal and surety have signed and sealed this instrument this _____ day of _____, 20_____ .

ATTEST:

Principal

(Principal) Secretary

By

Witness as to Principal

ATTEST:

Surety

By _____
Attorney-in-Fact

(Surety) Secretary

(Seal)

Witness as to Surety

NOTE: Date of Bond must not be prior to date of Contract. If Contractor is Partnership, all partners should execute bond.

IMPORTANT: Surety companies executing Bond must appear on the Treasury Department's most current list (Circular 570 as amended) and be authorized to transact business in the State of Rhode Island.

*Pawtucket Housing Authority
St. Germain Manor Deck Improvements
Pawtucket, Rhode Island*

PEFORMANCE BOND

*Pawtucket Housing Authority
St. Germain Manor Deck Improvements
Pawtucket, Rhode Island*

PERFORMANCE BOND

KNOW ALL MEN BY THESE PRESENTS, that _____ (Name of Contractor)
of

(Address of Contractor)

as Principal hereinafter called Principal, and _____ of

(Name of Surety)

(Address of Surety)

_____, a Corporation, organized and existing under the laws of the State of hereinafter called Surety, are held and firmly bound unto the *Pawtucket Housing Authority*, called the Oblige, in the full penal sum of _____ Dollars (\$_____), in lawful money of their heirs, executors, administrators, successors and assigns, jointly and severally, firmly by these presents.

THE CONDITION OF THIS OBLIGATION IS MUCH THAT WHEREAS said Principal has entered into a certain written contract with said Oblige, dated the _____ day of _____, 20____ for the **PAWTUCKET HOUSING AUTHORITY ST. GERMAIN MANOR DECK IMPROVEMENTS** project which contract, together with all Contract Documents now made or which may hereafter be made in extension, modification or alternation thereof, are hereby referred to, incorporated in and made a part of this bond as though herein fully set forth.

NOW, THEREFORE, if the said Principal shall well and truly keep, perform and execute all the terms, conditions and stipulations of said contract according to its provisions on his or its part to be kept and performed and shall indemnify and reimburse the obligee for any loss that it may suffer through failure of the principal to faithfully observe and perform each and every obligation and duty imposed upon the Principal by the said contract, at the time and in the manner therein specified, then this obligation shall be null and void, otherwise it shall remain and be in full force and effect.

PROVIDED, HOWEVER, that any alternations which may be made in the terms of said contract or in the work done or to be done under it, or the giving by the Oblige of any extension of time for the performance of said Contract or any other forbearance on the part of either the Oblige or the Principal one to the others, shall not in any way released the Principal and/or the Surety, or either of them, their representative, heirs executors, administrators, successors or assigns from liability hereunder, notice to the Surety or Sureties of any such alteration, extension or forbearance being hereby specifically and absolutely waived.

AND PROVIDED FURTHER THAT NO ACTION, suit or proceeding shall be had or maintained against the Surety on this instrument unless the same be brought or instituted and process served upon the Surety within three years from the expiration of the guaranty period provided in the contract, whether the work be completed by the Principal, or Oblige.

*Pawtucket Housing Authority
St. Germain Manor Deck Improvements
Pawtucket, Rhode Island*

IN WITNESS WHEREOF, the said principal and surety have signed and sealed this instrument this _____ day of _____, 20_____ .

ATTEST:

Principal

(Principal) Secretary

By

Witness as to Principal

ATTEST:

Surety

By _____
Attorney-in-Fact

(Surety) Secretary

(Seal)

Witness as to Surety

NOTE: Date of Bond must not be prior to date of Contract. If Contractor is Partnership, all partners should execute bond.

IMPORTANT: Surety companies executing Bond must appear on the Treasury Department's most current list (Circular 570 as amended) and be authorized to transact business in the State of Rhode Island.

*Pawtucket Housing Authority
St. Germain Manor Deck Improvements
Pawtucket, Rhode Island*

NOTICE OF AWARD

TO: _____

PROJECT DESCRIPTION: PAWTUCKET HOUSING AUTHORITY ST. GERMAIN MANOR DECK IMPROVEMENTS PROJECT

The OWNER has considered the BID submitted by you for the above-referenced WORK in response to its invitation for Bids.

You are hereby notified that your BID has been accepted for items in the amounts shown in the Bid Schedule.

You are required by the Information for Bidders to execute the Agreement and furnish the required CONTRACTOR'S PERFORMANCE BOND, PAYMENT BOND and certificates of insurance within ten (10) calendar days from the date of this Notice to you.

If you fail to execute said Agreement and to furnish said BONDS within ten (10) days from the date of this NOTICE, said OWNER will be entitled to consider all your rights arising out of the OWNER'S acceptance of your BID as abandoned and as a forfeiture of your BID BOND. The OWNER will be entitled to such other rights as may be granted by law.

You are required to return an acknowledged copy of this NOTICE OF AWARD to the OWNER.

Dated this day of _____, 20__.

Pawtucket Housing Authority.
OWNER

BY: _____

TITLE: _____

ACCEPTANCE OF NOTICE

Receipt of the above NOTICE OF AWARD is hereby acknowledged by this the ____ day of _____, 20__.

BY: _____

TITLE: _____

NOTICE TO PROCEED

*Pawtucket Housing Authority
St. Germain Manor Deck Improvements
Pawtucket, Rhode Island*

Notice to Proceed - 1

NOTICE TO PROCEED

TO: _____

DATE:

PROJECT: St. germain Manor Deck
Improvements

You are hereby notified to commence WORK in accordance with the Agreement dated _____, on or before _____, and you are to complete the work by, _____, 20__.

Pawtucket Housing Authority, Pawtucket, Rhode Island
OWNER

BY: _____

TITLE: _____

ACCEPTANCE OF NOTICE

Receipt of the above NOTICE TO PROCEED IS
Hereby acknowledged by:

Contractor's Company Name Printed

this the _____ day of _____, 20__ .

By: _____

Title: _____

HUD DOCUMENTS

*Pawtucket Housing Authority
St. Germain Manor Deck Improvements
Pawtucket, Rhode Island*

HUD Documents - 1

HUD DOCUMENTS

#

*Pawtucket Housing Authority
Galego Court Roof Replacement
Pawtucket, Rhode Island*

HUD Documents - 1

General Contract Conditions for Small Construction/Development Contracts

U.S. Department of Housing and Urban Development
Office of Public and Indian Housing
OMB Approval No. 2577-0157 (exp. 3/31/2020)

Applicability. The following contract clauses are applicable and must be inserted into small construction/development contracts greater than \$2,000 but not more than \$150,000.

1. Definitions

Terms used in this form are the same as defined in form HUD-5370

2. Prohibition Against Liens

The Contractor is prohibited from placing a lien on the PHA's property. This prohibition shall apply to all subcontractors at any tier and all materials suppliers. The only liens on the PHA's property shall be the Declaration of Trust or other liens approved by HUD.

3. Disputes

- (a) Except for disputes arising under the **Labor Standards** clauses, all disputes arising under or relating to this contract, including any claims for damages for the alleged breach thereof which are not disposed of by agreement, shall be resolved under this clause.
- (b) All claims by the Contractor shall be made in writing and submitted to the Contracting Officer for a written decision. A claim by the PHA against the Contractor shall be subject to a written decision by the Contracting Officer.
- (c) The Contracting Officer shall, within 30 days after receipt of the request, decide the claim or notify the Contractor of the date by which the decision will be made.
- (d) The Contracting Officer's decision shall be final unless the Contractor (1) appeals in writing to a higher level in the PHA in accordance with the PHA's policy and procedures, (2) refers the appeal to an independent mediator or arbitrator, or (3) files suit in a court of competent jurisdiction. Such appeal must be made within 30 days after receipt of the Contracting Officer's decision.
- (e) The Contractor shall proceed diligently with performance of this contract, pending final resolution of any request for relief, claim, appeal, or action arising under or relating to the contract, and comply with any decision of the Contracting Officer.

4. Default

- (a) If the Contractor refuses or fails to prosecute the work, or any separable part thereof, with the diligence that will insure its completion within the time specified in this contract, or any extension thereof, or fails to complete said work within this time, the Contracting Officer may, by written notice to the Contractor, terminate the right to proceed with the work (or separable part of the work) that has been delayed. In the event, the PHA may take over the work and complete it by contract or otherwise, and may take possession of and use any materials, equipment, and plant on the work site necessary for completing the work. The Contractor and its sureties shall be liable for any damage to the PHA resulting from the Contractor's refusal or failure to complete the work within the specified time, whether or not the Contractor's right to proceed with the work is terminated. This liability includes any increased costs incurred by the PHA in completing the work.

- (b) The Contractor's right to proceed shall not be terminated or the Contractor charged with damages under this clause if –
 - (1) The delay in completing the work arises from unforeseeable causes beyond the control and without the fault or negligence of the Contractor; and
 - (2) The Contractor, within 10 days from the beginning of such delay notifies the Contracting Officer in writing of the causes of delay. The Contracting Officer shall ascertain the facts and the extent of the delay. If, in the judgment of the Contracting Officer, the findings of Fact warrant such action, time for completing the work shall be extended by written modification to the contract. The findings of the Contracting Officer shall be reduced to a written decision which shall be subject to the provisions of the **Disputes** clause of this contract.
- (c) If, after termination of the Contractor's right to proceed, it is determined that the Contractor was not in default, or that the delay was excusable, the rights and obligation of the parties will be the same as if the termination had been for convenience of the PHA.

5. Termination for Convenience

- (a) The Contracting Officer may terminate this contract in whole, or in part, whenever the Contracting Officer determines that such termination is in the best interest of the PHA. Any such termination shall be effected by delivery to the Contractor of a Notice of Termination specifying the extent to which the performance of the work under the contract is terminated, and the date upon which such termination becomes effective.
- (b) If the performance of the work is terminated, either in whole or in part, the PHA shall be liable to the Contractor for reasonable and proper costs resulting from such termination upon the receipt by the PHA of a properly presented claim setting out in detail: (1) the total cost of the work performed to date of termination less the total amount of contract payments made to the Contractor; (2) the cost (including reasonable profit) of settling and paying claims under subcontracts and material orders for work performed and materials and supplies delivered to the site, payment for which has not been made by the PHA to the Contractor or by the Contractor to the subcontractor or supplier; (3) the cost of preserving and protecting the work already performed until the PHA or assignee takes possession thereof or assumes responsibility therefore; (4) the actual or estimated cost of legal and accounting services reasonably necessary to prepare and present the termination claim to the PHA; and (5) an amount constituting a reasonable profit on the value of the work performed by the Contractor.
- (c) The Contracting Officer will act on the Contractor's claim within days (60 days unless otherwise indicated) of receipt of the Contractor's claim.
- (d) Any disputes with regard to this clause are expressly made subject to the provisions of the Disputes clause of this contract.

6. Insurance

- (a) Before commencing work, the Contractor and each subcontractor shall furnish the PHA with certificates of insurance showing the following insurance is in force and will insure all operations under the Contract:

(1) Workers' Compensation, in accordance with state or Territorial Workers' Compensation laws.

(2) Commercial General Liability with a combined single limit for bodily injury and property damage of not less than \$ _____ [Contracting Officer insert amount] per occurrence to protect the Contractor and each subcontractor against claims for bodily injury or death and damage to the property of others. This shall cover the use of all equipment, hoists, and vehicles on the site(s) not covered by Automobile Liability under (3) below. If the Contractor has a "claims-made" policy, then the following additional requirements apply: the policy must provide a "retroactive date" which must be on or before the execution date of the Contract; and the extended reporting period may not be less than five years following the completion date of the Contract.

(3) Automobile Liability on owned and non-owned motor vehicles used on the site(s) or in connection therewith for a combined single limit for bodily injury and property damage of not less than \$ _____ [Contracting Officer insert amount] per occurrence.

(b) Before commencing work, the Contractor shall furnish the PHA with a certificate of insurance evidencing that Builder's Risk (fire and extended coverage) Insurance on all work in place and/or materials stored at the building site(s), including foundations and building equipment, is in force. The Builder's Risk Insurance shall be for the benefit of the Contractor and the PHA as their interests may appear and each shall be named in the policy or policies as an insured. The Contractor in installing equipment supplied by the PHA shall carry insurance on such equipment from the time the Contractor takes possession thereof until the Contract work is accepted by the PHA. The Builder's Risk Insurance need not be carried on excavations, piers, footings, or foundations until such time as work on the superstructure is started. It need not be carried on landscape work. Policies shall furnish coverage at all times for the full cash value of all completed construction, as well as materials in place and/or stored at the site(s), whether or not partial payment has been made by the PHA. The Contractor may terminate this insurance on buildings as of the date taken over for occupancy by the PHA. The Contractor is not required to carry Builder's Risk Insurance for modernization work which does not involve structural alterations or additions and where the PHA's existing fire and extended coverage policy can be endorsed to include such work.

(c) All insurance shall be carried with companies which are financially responsible and admitted to do business in the State in which the project is located. If any such insurance is due to expire during the construction period, the Contractor (including subcontractors, as applicable) shall not permit the coverage to lapse and shall furnish evidence of coverage to the Contracting Officer. All certificates of insurance, as evidence of coverage, shall provide that no coverage may be canceled or non-renewed by the insurance company until at least 30 days prior written notice has been given to the Contracting Officer.

7. Contract Modifications

(a) Only the Contracting Officer has authority to modify any term or condition of this contract. Any contract modification shall be authorized in writing.

(b) The Contracting Officer may modify the contract unilaterally (1) pursuant to a specific authorization stated in a contract clause (e.g., Changes); or (2) for administrative matters which

do not change the rights or responsibilities of the parties (e.g., change in the PHA address). All other contract modifications shall be in the form of supplemental agreements signed by the Contractor and the Contracting Officer.

(c) When a proposed modification requires the approval of HUD prior to its issuance (e.g., a change order that exceeds the PHA's approved threshold), such modification shall not be effective until the required approval is received by the PHA.

8. Changes

(a) The Contracting Officer may, at any time, without notice to the sureties, by written order designated or indicated to be a change order, make changes in the work within the general scope of the contract including changes:

(1) In the specifications (including drawings and designs);

(2) In the method or manner of performance of the work;

(3) PHA-furnished facilities, equipment, materials, services, or site; or,

(4) Directing the acceleration in the performance of the work.

(b) Any other written order or oral order (which, as used in this paragraph (b), includes direction, instruction, interpretation, or determination) from the Contracting Officer that causes a change shall be treated as a change order under this clause; provided, that the Contractor gives the Contracting Officer written notice stating (1) the date, circumstances and source of the order and (2) that the Contractor regards the order as a change order.

(c) Except as provided in this clause, no order, statement or conduct of the Contracting Officer shall be treated as a change under this clause or entitle the Contractor to an equitable adjustment.

(d) If any change under this clause causes an increase or decrease in the Contractor's cost of, or the time required for the performance of any part of the work under this contract, whether or not changed by any such order, the Contracting Officer shall make an equitable adjustment and modify the contract in writing. However, except for an adjustment based on defective specifications, no proposal for any change under paragraph (b) above shall be allowed for any costs incurred more than 20 days (5 days for oral orders) before the Contractor gives written notice as required. In the case of defective specifications for which the PHA is responsible, the equitable adjustment shall include any increased cost reasonably incurred by the Contractor in attempting to comply with the defective specifications.

(e) The Contractor must assert its right to an adjustment under this clause within 30 days after (1) receipt of a written change order under paragraph (a) of this clause, or (2) the furnishing of a written notice under paragraph (b) of this clause, by submitting a written statement describing the general nature and the amount of the proposal. If the facts justify it, the Contracting Officer may extend the period for submission. The proposal may be included in the notice required under paragraph (b) above. No proposal by the Contractor for an equitable adjustment shall be allowed if asserted after final payment under this contract.

(f) The Contractor's written proposal for equitable adjustment shall be submitted in the form of a lump sum proposal supported with an itemized breakdown of all increases and decreases in the contract in at least the following details:

(1) Direct Costs. Materials (list individual items, the quantity and unit cost of each, and the aggregate cost); Transportation and delivery costs associated with materials; Labor

-
- qualifications for each; and the name and location of the person(s) taking applications for each of the positions; and the anticipated date the work shall begin.
- (d) The contractor agrees to include this section 3 clause in every subcontract subject to compliance with regulations in 24 CFR Part 135, and agrees to take appropriate action, as provided in an applicable provision of the subcontract or in this section 3 clause, upon a finding that the subcontractor is in violation of the regulations in 24 CFR Part 135. The contractor will not subcontract with any subcontractor where the contractor has notice or knowledge that the subcontractor has been found in violation of the regulations in 24 CFR Part 135.
 - (e) The contractor will certify that any vacant employment positions, including training positions, that are filled (1) after the contractor is selected but before the contract is executed, and (2) with persons other than those to whom the regulations of 24 CFR Part 135 require employment opportunities to be directed, were not filled to circumvent the contractor's obligations under 24 CFR Part 135.
 - (f) Noncompliance with HUD's regulations in 24 CFR Part 135 may result in sanctions, termination of this contract for default, and debarment or suspension from future HUD assisted contracts.

14. Labor Standards - Davis-Bacon and Related Acts

(a) Minimum Wages.

(1) All laborers and mechanics employed under this contract in the construction or development of the project(s) involved will be paid unconditionally and not less often than once a week, and without subsequent deduction or rebate on any account (except such payroll deductions as are permitted by regulations issued by the Secretary of Labor under the Copeland Act (29 CFR Part 3)), the full amount of wages and bona fide fringe benefits (or cash equivalents thereof) due at time of payment computed at rates not less than those contained in the wage determination of the Secretary of Labor which is attached hereto and made a part hereof, regardless of any contractual relationship which may be alleged to exist between the Contractor and such laborers and mechanics. Contributions made or costs reasonably anticipated for bona fide fringe benefits under Section 1(b)(2) of the Davis-Bacon Act on behalf of laborers or mechanics are considered wages paid to such laborers or mechanics, subject to the provisions of 29 CFR 5.5(a)(1)(iv); also, regular contributions made or costs incurred for more than a weekly period (but not less often than quarterly) under plans, funds, or programs which cover the regular weekly period, are deemed to be constructively made or incurred during such weekly period. Such laborers and mechanics shall be paid the appropriate wage rate and fringe benefits in the wage determination for the classification of work actually performed, without regard to skill, except as provided in 29 CFR 5.5(a)(4). Laborers or mechanics performing work in more than one classification may be compensated at the rate specified for each classification for the time actually worked therein; provided, that the employer's payroll records accurately set forth the time spent in each classification in which work is performed. The wage determination (including any additional classification and wage rates conformed under 29 CFR 5.5(a)(1)(ii) and the Davis-Bacon poster (WH-1321) shall be posted at all times by the Contractor and its subcontractors at the site of the work in

a prominent and accessible place where it can be easily seen by the workers.

- (2) (i) Any class of laborers or mechanics, including helpers, which is not listed in the wage determination and which is to be employed under the contract shall be classified in conformance with the wage determination. HUD shall approve an additional classification and wage rate and fringe benefits therefor only when all the following criteria have been met:

- (a) The work to be performed by the classification requested is not performed by a classification in the wage determination; and
- (b) The classification is utilized in the area by the construction industry; and
- (c) The proposed wage rate, including any bona fide fringe benefits, bears a reasonable relationship to the wage rates contained in the wage determination.

- (ii) If the Contractor and the laborers and mechanics to be employed in the classification (if known), or their representatives, and HUD or its designee agree on the classification and wage rate (including the amount designated for fringe benefits where appropriate), a report of the action shall be sent by HUD or its designee to the Administrator of the Wage and Hour Division, Employee Standards Administration, U.S. Department of Labor, Washington, DC 20210. The Administrator, or an authorized representative, will approve, modify, or disapprove every additional classification action within 30 days of receipt and so advise HUD or its designee or will notify HUD or its designee within the 30-day period that additional time is necessary.

- (iii) In the event the Contractor, the laborers or mechanics to be employed in the classification or their representatives, and HUD or its designee do not agree on the proposed classification and wage rate (including the amount designated for fringe benefits, where appropriate), HUD or its designee shall refer the questions, including the views of all interested parties and the recommendation of HUD or its designee, to the Administrator of the Wage and Hour Division for determination. The Administrator, or an authorized representative, will issue a determination within 30 days of receipt and so advise HUD or its designee or will notify HUD or its designee within the 30-day period that additional time is necessary.

- (iv) The wage rate (including fringe benefits where appropriate) determined pursuant to subparagraphs (a)(2)(ii) or (iii) of this clause shall be paid to all workers performing work in the classification under this contract from the first day on which work is performed in the classification.

- (3) Whenever the minimum wage rate prescribed in the contract for a class of laborers or mechanics includes a fringe benefit which is not expressed as an hourly rate, the Contractor shall either pay the benefit as stated in the wage determination or shall pay another bona fide fringe benefit or an hourly cash equivalent thereof.

- (4) If the Contractor does not make payments to a trustee or other third person, the Contractor may consider as part

of the wages of any laborer or mechanic the amount of any costs reasonably anticipated in providing bona fide fringe benefits under a plan or program; *provided*, that the Secretary of Labor has found, upon the written request of the Contractor, that the applicable standards of the Davis-Bacon Act have been met. The Secretary of Labor may require the Contractor to set aside in a separate account assets for the meeting of obligations under the plan or program.

(b) **Withholding of Funds.** HUD or its designee shall, upon its own action or upon written request of an authorized representative of the Department of Labor, withhold or cause to be withheld from the Contractor under this contract or any other Federal contract with the same prime Contractor, or any other Federally-assisted contract subject to Davis-Bacon prevailing wage requirements, which is held by the same prime Contractor, so much of the accrued payments or advances as may be considered necessary to pay laborers and mechanics, including apprentices, trainees, and helpers, employed by the Contractor or any subcontractor the full amount of wages required by the contract. In the event of failure to pay any laborer or mechanic, including any apprentice, trainee, or helper, employed or working in the construction or development of the project, all or part of the wages required by the contract, HUD or its designee may, after written notice to the Contractor, take such action as may be necessary to cause the suspension of any further payment, advance, or guarantee of funds until such violations have ceased. HUD or its designee may, after written notice to the Contractor, disburse such amounts withheld for and on account of the Contractor or subcontractor to the respective employees to whom they are due.

(c) **Payrolls and Basic Records.**

(1) Payrolls and basic records relating thereto shall be maintained by the Contractor during the course of the work and preserved for a period of three years thereafter for all laborers and mechanics working in the construction or development of the project. Such records shall contain the name, address, and social security number of each such worker, his or her correct classification, hourly rates of wages paid (including rates of contributions or costs anticipated for bona fide fringe benefits or cash equivalents thereof of the types described in section 1(b)(2)(B) of the Davis-Bacon Act), daily and weekly number of hours worked, deductions made, and actual wages paid. Whenever the Secretary of Labor has found, under 29 CFR 5.5(a)(1)(iv), that the wages of any laborer or mechanic include the amount of costs reasonably anticipated in providing benefits under a plan or program described in section 1(b)(2)(B) of the Davis-Bacon Act, the Contractor shall maintain records which show that the commitment to provide such benefits is enforceable, that the plan or program is financially responsible, and that the plan or program has been communicated in writing to the laborers or mechanics affected, and records which show the costs anticipated or the actual cost incurred in providing such benefits. Contractors employing apprentices or trainees under approved programs shall maintain written evidence of

the registration of apprenticeship programs and certification of trainee programs, the registration of the apprentices and trainees, and the ratios and wage rates prescribed in the applicable programs.

- (2) (i) The Contractor shall submit weekly for each week in which any contract work is performed a copy of all payrolls to the Contracting Officer for transmission to HUD or its designee. The payrolls submitted shall set out accurately and completely all of the information required to be maintained under subparagraph (c)(1) of this clause. This information may be submitted in any form desired. Optional Form WH-347 (Federal Stock Number 029-005-00014-1) is available for this purpose and may be purchased from the Superintendent of Documents, U.S. Government Printing Office, Washington, D.C. 20402. The prime Contractor is responsible for the submission of copies of payrolls by all subcontractors. (Approved by the Office of Management and Budget under OMB Control Number 1214-0149.)
- (ii) Each payroll submitted shall be accompanied by a "Statement of Compliance," signed by the contractor or subcontractor or his or her agent who pays or supervises the payment of the persons employed under the contract and shall certify the following:
- (A) That the payroll for the payroll period contains the information required to be maintained under paragraph (c)(1) of this clause and that such information is correct and complete;
- (B) That each laborer or mechanic (including each helper, apprentice, and trainee) employed on the contract during the payroll period has been paid the full weekly wages earned, without rebate, either directly or indirectly, and that no deductions have been made either directly or indirectly from the full wages earned, other than permissible deductions as set forth in 29 CFR Part 3; and
- (C) That each laborer or mechanic has been paid not less than the applicable wage rates and fringe benefits or cash equivalents for the classification of work performed, as specified in the applicable wage determination incorporated into the contract.
- (iii) The weekly submission of a properly executed certification set forth on the reverse side of Optional Form WH-347 shall satisfy the requirements for submission of the "Statement of Compliance" required by subparagraph (c)(2)(ii) of this clause.
- (iv) The falsification of any of the above certifications may subject the Contractor or subcontractor to civil or criminal prosecution under Section 1001 of Title 18 and Section 3729 of Title 31 of the United States Code.
- (3) The Contractor or subcontractor shall make the records required under subparagraph (c)(1) available for inspection, copying, or transcription by authorized representatives of HUD or its designee, the Contracting Officer, or the Department of Labor and shall permit such representatives to interview employees during working hours on the job. If the Contractor or subcontractor fails to submit the required records or to make them available, HUD or its designee may, after written notice to the Contractor, take such action as may be necessary to cause the suspension of any further payment, advance, or guarantee of funds. Furthermore, failure to submit the required records upon request or to make such records available may be grounds for debarment action pursuant to 29 CFR 5.12.

- (d) Apprentices. Apprentices will be permitted to work at less than the predetermined rate for the work they performed when they are employed pursuant to and individually registered in a bona fide apprenticeship program registered with the U.S. Department of Labor, Employment and Training Administration, Office of Apprenticeship Training, Employer and Labor Services (OATELS), or with a State Apprenticeship Agency recognized by OATELS, or if a person is employed in his or her first 90 days of probationary employment as an apprentice in such an apprenticeship program, who is not individually registered in the program, but who has been certified by OATELS or a State Apprenticeship Agency (where appropriate) to be eligible for probationary employment as an apprentice.
- The allowable ratio of apprentices to journeymen on the job site in any craft classification shall not be greater than the ratio permitted to the Contractor as to the entire work force under the registered program. Any worker listed on a payroll at an apprentice wage rate, who is not registered or otherwise employed as stated in this paragraph, shall be paid not less than the applicable wage rate on the wage determination for the classification of work actually performed. In addition, any apprentice performing work on the job site in excess of the ratio permitted under the registered program shall be paid not less than the applicable wage rate on the wage determination for the work actually performed. Where a contractor is performing construction on a project in a locality other than that in which its program is registered, the ratios and wage rates (expressed in percentages of the journeyman's hourly rate) specified in the Contractor's or subcontractor's registered program shall be observed. Every apprentice must be paid at not less than the rate specified in the registered program for the apprentice's level of progress, expressed as a percentage of the journeyman hourly rate specified in the applicable wage determination. Apprentices shall be paid fringe benefits in accordance with the provisions of the apprenticeship program. If the apprenticeship program does not specify fringe benefits, apprentices must be paid the full amount of fringe benefits listed on the wage determination for the applicable classification. If the Administrator of the Wage and Hour Division determines that a different practice prevails for the applicable apprentice classification, fringes shall be paid in accordance with that determination. In the event OATELS, or a State Apprenticeship Agency recognized by OATELS, withdraws approval of an apprenticeship program, the Contractor will no longer be permitted to utilize apprentices at less than the applicable predetermined rate for the work performed until an acceptable program is approved.

- (e) Trainees. Except as provided in 29 CFR 5.16, trainees will not be permitted to work at less than the predetermined rate for the work performed unless they are employed pursuant to and individually registered in a program which has received prior approval, evidenced by formal certification by the U.S. Department of Labor, Employment and Training Administration. The ratio of trainees to journeymen on the job site shall not be greater than permitted under the plan approved by the Employment and Training Administration. Every trainee must be paid at not less than the rate specified in the approved program for the trainee's level of progress, expressed as a percentage of the journeyman hourly rate

specified in the applicable wage determination. Trainees shall be paid fringe benefits in accordance with the provisions of the trainee program. If the trainee program does not mention fringe benefits, trainees shall be paid the full amount of fringe benefits listed in the wage determination unless the Administrator of the Wage and Hour Division determines that there is an apprenticeship program associated with the corresponding journeyman wage rate in the wage determination which provides for less than full fringe benefits for apprentices. Any employee listed on the payroll at a trainee rate who is not registered and participating in a training plan approved by the Employment and Training Administration shall be paid not less than the applicable wage rate in the wage determination for the classification of work actually performed. In addition, any trainee performing work on the job site in excess of the ratio permitted under the registered program shall be paid not less than the applicable wage rate in the wage determination for the work actually performed. In the event the Employment and Training Administration withdraws approval of a training program, the Contractor will no longer be permitted to utilize trainees at less than the applicable predetermined rate for the work performed until an acceptable program is approved.

- (f) Equal Employment Opportunity. The utilization of apprentices, trainees, and journeymen under this clause shall be in conformity with the equal employment opportunity requirements of Executive Order 11246, as amended, and 29 CFR Part 30.
- (g) Compliance with Copeland Act Requirements. The Contractor shall comply with the requirements of 29 CFR Part 3, which are hereby incorporated by reference in this contract.
- (h) Contract Termination; Debarment. A breach of the labor standards clauses in this contract may be grounds for termination of the contract and for debarment as a Contractor and a subcontractor as provided in 29 CFR 5.12.
- (i) Compliance with Davis-Bacon and related Act Requirements. All rulings and interpretations of the Davis-Bacon and related Acts contained in 29 CFR Parts 1, 3, and 5 are herein incorporated by reference in this contract.
- (j) Disputes Concerning Labor Standards. Disputes arising out of the labor standards provisions of this clause shall not be subject to the general disputes clause of this contract. Such disputes shall be resolved in accordance with the procedures of the Department of Labor set forth in 29 CFR Parts 5, 6, and 7. Disputes within the meaning of this clause include disputes between the Contractor (or any of its subcontractors) and the PHA, HUD, the U.S. Department of Labor, or the employees or their representatives.
- (k) Certification of Eligibility.
- (1) By entering into this contract, the Contractor certifies that neither it (nor he or she) nor any person or firm who has an interest in the Contractor's firm is a person or firm ineligible to be awarded contracts by the United States Government by virtue of section 3(a) of the Davis-Bacon Act or 29 CFR 5.12(a)(1).
 - (2) No part of this contract shall be subcontracted to any person or firm ineligible for award of a United States Government

contract by virtue of section 3(a) of the Davis-Bacon Act or 29 CFR 5.12(a)(1).

(3) The penalty for making false statements is prescribed in the U. S. Criminal Code, 18 U.S.C. 1001.

(l) Subcontracts. The Contractor or subcontractor shall insert in any subcontracts all the provisions contained in this clause, and such other clauses as HUD or its designee may by appropriate instructions require, and also a clause requiring the subcontractors to include these provisions in any lower tier subcontracts. The prime Contractor shall be responsible for the compliance by any subcontractor or lower tier subcontractor with all these provisions.

(m) Non-Federal Prevailing Wage Rates. Any prevailing wage rate (including basic hourly rate and any fringe benefits), determined under State law to be prevailing, with respect to any employee in any trade or position employed under the contract, is inapplicable to the contract and shall not be enforced against the Contractor or any subcontractor, with respect to employees engaged under the contract whenever such non-Federal prevailing wage rate exceeds:

- (i) the applicable wage rate determined by the Secretary of Labor pursuant to the Davis-Bacon Act (40 U.S.C. 3141 et seq.) to be prevailing in the locality with respect to such trade;
- (ii) an applicable apprentice wage rate based thereon specified in an apprenticeship program registered with the U.S. Department of Labor (DOL) or a DOL-recognized State Apprenticeship Agency; or
- (iii) an applicable trainee wage rate based thereon specified in a DOL-certified trainee program.

Previous Participation Certification

U.S. Department of Housing and Urban Development
Office of Housing/Federal Housing Commissioner

U.S. Department of Agriculture
Farmers Home Administration

OMB Approval No. 2502-0118
(exp 11/30/2012)

Part I To be completed by Principals of Multifamily Projects. See Instructions Reason for Submitting Certification			For HUD HQ/FmHA use only	
1. Agency Name and City where the application is filed			2. Project Name, Project Number, City and Zip Code contained in the application	
3. Loan or Contract Amount	4. Number of Units or Beds	5. Section of Act	6. Type of Project (check one) <input type="checkbox"/> Existing <input type="checkbox"/> Rehabilitation <input type="checkbox"/> Proposed (New)	

List of UI dropped Principal Participants and attach organization chart for all organizations.

7. Names and Addresses of All Known Principals and Affiliates (people, businesses & organizations) proposing to participate in the project described above. (list names alphabetically; last, first, middle initial)	8. Role of Each Principal in Project	9. Expected % Ownership Interest in Project	10. Social Security or IRS Employer Number

Certifications: I (meaning the individual who signs as well as the corporations, partnerships or other parties listed above who certify) hereby apply to HUD or USDA FmHA, as the case maybe, for approval to participate as a principal in the role and project listed above based upon my following previous participation record and this Certification. Verify that neither you nor any of your principals or affiliates have ever been found to be in noncompliance with any applicable fair housing and civil rights requirements in 24 CFR 5.105 (a). If you or any of your principals or affiliates have been found to be in noncompliance with any such requirements, attach a signed statement explaining the relevant facts, circumstances, and resolution, if any. I certify that all the statements made by me are true, complete and correct to the best of my knowledge and belief and are made in good faith, including the data contained in Schedule A and Exhibits signed by me and attached to this form. **Y etplpi** < HUD will prosecute false claims and statements. Conviction may result in criminal and/or civil penalties. (18 U.S.C. 1001, 1010, 1012; 31U.S.C. 3729, 3802) I further certify that:

- Schedule A contains a listing of every assisted or

- insured project of HUD, USDA FmHA and State and local government housing finance agencies in which I have been or am now a principal.
- For the period beginning 10 years prior to the date of this certification, and except as shown by me on the certification.
 - No mortgage on a project listed by me has ever been in default, assigned to the Government or foreclosed, nor has mortgage relief by the mortgagee been given;
 - "Ijave not experienced defaults or noncompliances under any Conventional Contract or Turnkey Contract of Sale in connection with a public housing project;
 - To the best of my knowledge, there are no unresolved findings raised as a result of HUD audits, management reviews or other Governmental investigations concerning me or my projects;
 - There has not been a suspension or termination of payments under any HUD assistance contract in which I have had a legal or beneficial interest;
 - I have not been convicted of a felony and am not presently, to my knowledge, the subject of a

- complaint or indictment charging a felony. (A felony is defined as any offense punishable by imprisonment for a term exceeding one year, but does not include any offense classified as a misdemeanor under the laws of a State and punishable by imprisonment of two years or less);
- Have not been suspended, debarred or otherwise restricted by any Department or Agency of the Federal Government or of a State Government from doing business with such Department or Agency.
- I have not defaulted on an obligation covered by a surety or performance bond and have not been the subject of a claim under an employee fidelity bond.
- All the names of the parties, known to me to be principals in this project(s) in which I propose to participate, are listed above.
- I am not a HUD/FmHA employee or a member of a HUD/FmHA employee's immediate household as defined "in Standards of Ethical Conduct" for Employees of the Executive Branch in 5C.F.R. Part 2635 (57 FR 35006) and HUD's Standard of Conduct in 24 C.F.R. Part 2 and USDA's Standard of Conduct in 7 C.F.R. Part 2 Subpart B.

- I am not a principal participant in an assisted or insured project as of this date on which construction has stopped for a period in excess of 20 days or which has been substantially completed for more than 90 days and documents for closing, including final cost certification have not been filed with HUD or FmHA
- To my knowledge I have not been found by HUD or FmHA to be in noncompliance with any applicable fair housing and civil rights requirements in 24 CFR 5.107(a).
- I am not a Member of Congress or a Resident Commissioner nor otherwise prohibited or limited by law from contracting with the Government of the United States of America.
- "Statements above (if any) to which I cannot certify have been deleted by striking through the words with a pen. I have initialed each deletion (if any) and have attached a true and accurate signed statement (if applicable) to explain the facts and circumstances which I think helps to qualify me as a responsible principal for participation in this project.

Typed or Printed Name of Principal	Signature of Principal	Certification Date (mm/dd/yyyy)	Area Code and Telephone No.

This form was prepared by (Please print name) _____ Area Code and Telephone No. _____

Schedule A: List of Previous Projects and Section 8 Contracts. By my name below is the complete list of my previous projects and my participation history as a principal; in Multifamily Housing programs of HUD/FmHA, State, and Local Housing Finance Agencies. **Note:** Read and follow the instruction sheet carefully. Abbreviate where possible. Make full disclosure. Add extra sheets if you need more space. Double check for accuracy. If you have no previous projects write, by your name, "**No previous participation, First Experience.**"

1. List each Principal's Name (list in alphabetical order, last name first)	2. List Previous Projects (give the I.D. number, project name, city location, & government agency involved if other than HUD)	3. List Principals' Role(s) (indicate dates participated, and if fee or identity of interest participant)	4. Status of Loan (current, defaulted, assigned, or foreclosed)	5. Was Project ever in Default, during your participation?		6. Last Mgmt. and/or Physical Inspc'tn Rating and Date
				Yes	No If "Yes," explain	

Part II – For HUD Internal Processing Only

Received and checked by me for accuracy and completeness; recommend approval or transferral to Headquarters as checked below:

Date (mm/dd/yyyy)	Telephone Number and Area Code	<input type="checkbox"/> A. No adverse information; form HUD-2530 approval is recommended.	<input type="checkbox"/> C. Disclosure or Certification problem
Staff	Processing and Control	<input type="checkbox"/> B. Name match in system	<input type="checkbox"/> D. Other, our memorandum is attached.
Supervisor	Director of Housing / Director, Multifamily Division	Approved <input type="checkbox"/> Yes <input type="checkbox"/> No	Date (mm/dd/yyyy)

Instructions for Completing the Previous Participation Certificate, form HUD-2530

Carefully read these instructions and the applicable regulations. A copy of those regulations published at 24 C.F.R. 200.210 to 200.245 can be obtained from the Multifamily Housing Representative at any HUD Office. Type or print neatly in ink when filling out this form. Mark answers in all blocks of the form. If the form is not filled completely, it will delay approval of your application.

Attach extra sheets as you need them. Be sure to indicate "Continued on Attachments" wherever appropriate. Sign each additional page that you attach if it refers to you or your record. If you have many projects to list (20 or more) and expect to be applying frequently for participation in HUD projects, you should consider filing a Master List. See Master List instructions below under "Instructions for Completing Schedule A."

Carefully read the certification before you sign it. Any questions regarding the form or how to complete it can be answered by your HUD Office Multifamily Housing Representative.

Purpose: This form provides HUD with a certified report of all previous participation in HUD multifamily housing projects by those parties making application. The information requested in this form is used by HUD to determine if you meet the standards established to ensure that all principal participants in HUD projects will honor their legal, financial and contractual obligations and are acceptable risks from the underwriting standpoint of an insurer, lender or governmental agency. HUD requires that you certify your record of previous participation in HUD/USDA-FmHA, State and Local Housing Finance Agency projects by completing and signing this form, before your project application or participation can be approved.

HUD approval of your certification is a necessary precondition for your participation in the project and in the capacity that you propose. If you do not file this certification, do not furnish the information requested accurately, or do not meet established standards, HUD will not approve your certification.

Note that approval of your certification does not obligate HUD to approve your project application, and it does not satisfy all other HUD program requirements relative to your qualifications.

Who Must Sign and File Form HUD-2530:

Form HUD-2530 must be completed and signed by all parties applying to become principal participants in HUD multifamily housing projects, including those who have no previous participation. The form must be signed and filed by all principals and their affiliates who propose participating in the HUD project. Use a separate form for each role in the project unless there is an identity of interest.

Principals include all individuals, joint ventures, partnerships, corporations, trusts, non-profit organizations, any other public or private entity, that will participate in the proposed project as a sponsor, owner, prime contractor, turnkey developer, managing agent, nursing home administrator or operator, packager, or consultant. Architects and attorneys who have any interest in the project other than an arms length fee arrangement for professional services are also considered principals by HUD.

In the case of partnerships, all general partners regardless of their percentage interest and limited partners having a 25 percent or more interest in the partnership are considered principals. In the case of public or private corporations or governmental entities, principals include the president, vice president, secretary, treasurer and all other executive officers who are directly responsible to the board of directors, or any equivalent governing body, as well as all directors and each stockholder having a 10 percent or more interest in the corporation.

Affiliates are defined as any person or business concern that directly or indirectly controls the policy of a principal or has the power to do so. A holding or parent corporation would be an example of an affiliate if one of its subsidiaries is a principal.

Exception for Corporations – All principals and affiliates must personally sign the certificate except in the following situation. When a corporation is a principal, all of its officers, directors, trustees and stockholders with 10 percent or more of the common (voting) stock need not sign personally if they all have the same record to report. The officer who is authorized to sign for the corporation or agency will list the names and title of those who elect not to sign. However, any person who has a record of participation in HUD projects that is separate from that of his or her organization must report that activity on this form and sign his or her name. The objective is full disclosure.

Exemptions – The names of the following parties do not need to be listed on form HUD-2530: Public Housing Agencies, tenants, owners of less than five condominium or cooperative units and all others whose interests were acquired by inheritance or court order.

Where and When Form HUD-2530 Must Be Filed: The original of this form must be submitted to the HUD Office where your project application will be processed at the same time you file your initial project application. This form must be filed with applications for projects, or when otherwise required in the situations listed below:

- Projects to be financed with mortgages insured under the National Housing Act (FHA).
- Projects to be financed according to Section 202 of the Housing Act of 1959 (Elderly and Handicapped).
- Projects in which 20 percent or more of the units are to receive a subsidy as described in 24 C.F.R. 200.213.
- Purchase of a project subject to a mortgage insured or held by the Secretary of HUD.
- Purchase of a Secretary-owned project.
- Proposed substitution or addition of a principal, or principal participation in a different capacity from that previously approved for the same project.
- Proposed acquisition by an existing limited partner of an additional interest in a project resulting in a total interest of 25 percent or more, or proposed acquisition by a corporate stockholder of an additional interest in a project resulting in a total interest of 10 percent or more.
- Projects with U.S.D.A., Farmers Home Administration, or with state or local government housing finance agencies that include rental assistance under Section 8 of the Housing Act of 1937. For projects of this type, form HUD-2530 should be filed with the appropriate applications directly to those agencies.

Review of Adverse Determination: If approval of your participation in a HUD project is denied, withheld, or conditionally granted on the basis of your record of previous participation, you will be notified by the HUD Office. You may request reconsideration by the HUD Review Committee. Alternatively, you may request a hearing before a Hearing Officer. Either request must be made in writing within 30 days from your receipt of the notice of determination.

If you do request reconsideration by the Review Committee and the reconsideration results in an adverse determination, you may then request a hearing before a Hearing Officer. The Hearing Officer will issue a report to the Review Committee. You will be notified of the final ruling by certified mail.

Specific Line Instructions:

Reason for submitting this Certification: e.g., refinance, management, change in ownership, transfer of physical assets, etc.

Block 1: Fill in the name of the agency to which you are applying. For example: HUD Office, Farmers Home Administration District office, or the name of a State or local housing finance agency. Below that, fill in the name of the city where the office is located.

Block 2: Fill in the name of the project, such as "Greenwood Apts." If the name has not yet been selected, write "Name unknown." Below that, enter the HUD contract or project identification number, the Farmers Home Administration project number, or the State or local housing finance agency project or contract number. Include all project or contract identification numbers that are relevant to the project. Also enter the name of the city in which the project is located, and the ZIP Code of the site location.

Block 3: Fill in the dollar amount requested in the proposed mortgage, or the annual amount of rental assistance requested.

Block 4: Fill in the number of apartment units proposed, such as "40 units." For hospital projects or nursing homes, fill in the number of beds proposed, such as "100 beds."

Block 5: Fill in the section of the Housing Act under which the application is filed.

Block 7: Definitions of all those who are considered principals and affiliates are given above in the section titled "Who Must Sign and File...."

Block 8: Beside the name of each principal, fill in the role that each will perform. The following are possible roles that the principals may perform: Sponsor, Owner, Prime Contractor, Turnkey Developer, Managing Agent, Packager, Consultant, General Partner, Limited Partner (include percentage), Executive Officer, Director, Trustee, Major Stockholder, or Nursing Home Administrator. Beside the name of each affiliate, write the name of the person or firm of affiliation, such as "Affiliate of Smith Construction Co."

Block 9: Fill in the percentage of ownership in the proposed project that each principal is expected to have. Also specify if the participant is a general or limited partner. Beside the name of those parties who will not be owners, write "None."

Block 10: Fill in the Social Security Number or IRS employer number of every party listed, including affiliates.

Instructions for Completing Schedule A:

Be sure that Schedule A is filled-in completely, accurately and the certification is properly dated and signed, because it will serve as a legal record of your previous experience. All Multifamily Housing projects involving HUD/FmHA, and State and local Housing Finance Agencies in which you have previously participated **must** be listed. Applicants are reminded that previous participation pertains to the individual principal within an entity as well as the entity itself. A newly formed company may not have previous participation, but the principals within the company may have had extensive participation and disclosure of that activity is required. To avoid duplication of disclosure, list the project and then the entities or individuals involved in that project. You may use the name or a number code to denote the entity or individual that participated. The number code can then be used in column 3 to denote role.

Column 2 List the project or contract identification of each previous project. **All previous projects must be included or your certification cannot be processed.** Include the name of all projects, the cities in which they are located and the government agency (HUD, USDA-FmHA or State or local housing finance agency) that was involved. At the end of your list of projects, draw a straight line across the page to separate your record of projects from that of others signing this form who have a different record to report.

Column 3 List the role(s) of your participation, dates participated, and if fee or identity of interest with owners.

Column 4 Indicate the current status of the loan. Except for current loans, the date associated with the status is required. Loans under a workout arrangement are considered assigned. An explanation of the circumstances surrounding the status is required for all non-current loans.

Column 5 Explain any project defaults during your participation.

Column 6 Enter the latest Management and/or Physical Inspection Review rating. If either of the ratings are below average, the report issued by HUD is required to be submitted along with the applicant's explanation of the circumstances surrounding the rating.

No Previous Record: Even if you have never participated in a HUD project before, you must complete form HUD-2530. If you have no record of previous projects to list, fill in your name in column 1 of Schedule A, and write across the form by your name – "No previous participation, first experience."

Master List System: If you expect to file this form frequently and you have a long list of previous projects to report on Schedule A, you should consider filing a Master List. By doing so, you will avoid having to list all your previous projects each time you file a new application.

To make a Master List, use form HUD-2530. On page 1, in block 1, enter (in capital letters) the words "Master List." In blocks 2 through 6 enter in "N.A." meaning Not Applicable. Complete blocks 7 through 10.

In the box below the statement of certification, fill in the names of all parties who wish to file a Master List together (type or print neatly). Beside each name, every party must sign the form. In the box titled "Proposed Role," fill in "N.A." Also, fill in the date you sign the form

and provide a telephone number where you can be reached during the day. No determinations will be made on these certificates.

File one copy of the Master List with each HUD Office where you do business and mail one copy to the following address:

**HUD-2530 Master List
Participation and Compliance
Division – Housing
U.S. Department of Housing and
Urban Development
451 Seventh Street, S.W.
Washington, D.C. 20410**

Once you have filed a Master List, you do not need to complete Schedule A when you submit form HUD-2530. Instead, write the name of the participant in column 1 of Schedule A and beside that write "See Master List on file." Also give the date that appears on the Master List that you submitted. Below that, report all changes and additions that have occurred since that date. Be sure to include any mortgage defaults, assignments or foreclosures not listed previously.

If you have withdrawn from a project since the date the Master List was filed, be sure to name the project. Give the project identification number, the month and year your participation began and/or ended.

Certification:

After you have completed all other parts of form HUD-2530, including Schedule A, read the Certification carefully. In the box below the statement of certification, fill in the name of all principals and affiliates (type or print neatly). Beside the name of each principal and affiliate, each party must sign the form, with the exception in some cases of individuals associated with a corporation (see "Exception for Corporations" in the section of the instructions titled "Who Must Sign and File form

HUD-2530"). Beside each signature, fill in the role of each party (the same as shown in block 8). In addition, each person who signs the form should fill in the date that he or she signs, as well as providing a telephone number where he or she can be reached during business hours. By providing a telephone number where you can be reached, you will help to prevent any possible delay caused by mailing and processing time in the event HUD has any questions.

If you cannot certify and sign the certification as it is printed because some statements do not correctly describe your record, use a pen and strike through those parts that differ with your record, then sign and certify to that remaining part which does describe you or your record.

Attach a signed letter, note or an explanation of the items you have struck out on the certification and report the facts of your correct record. Item A(2)(e) relates to felony convictions within the past 10 years. If you have been convicted of a felony within 10 years, strike out all of A(2)(e) on the certificate and attach your statement giving your explanation. A felony conviction will not necessarily cause your participation to be disapproved unless there is a criminal record or other evidence that your previous conduct or method of doing business has been such that your participation in the project would make it an unacceptable risk from the underwriting standpoint of an insurer, lender or governmental agency.

The Department of Housing and Urban Development (HUD) is authorized to collect this information by law (42 U.S.C. 3535(d) and 24 C.F.R. 200.217) and by regulation at 24 CFR 200.210. This information is needed so that principals applying to participate in multifamily programs can become HUD-approved participants. The information you provide will enable HUD to evaluate your record with respect to established standards of performance, responsibility and eligibility. Without prior approval, a principal may not participate in a proposed or existing multifamily project. HUD uses this information to evaluate whether or not principals pose an unsatisfactory underwriting risk. The information is used to evaluate the potential principals and approve only individuals and organizations who will honor their legal, financial and contractual obligations.

Privacy Act Statement: The Housing and Community Development Act of 1987, 42 U.S.C. 3543 requires persons applying for a Federally-insured or guaranteed loan to furnish his/her Social Security Number (SSN). HUD must have your SSN for identification of your records. HUD may use your SSN for automated processing of your records and to make requests for information about you and your previous records with other public agencies and private sector sources. HUD may disclose certain information to Federal, State and local agencies when relevant to civil, criminal, or regulatory investigations and prosecutions. It will not be otherwise disclosed or released outside of HUD, except as required and permitted by law. You must provide all of the information requested in this application, including your SSN.

Public reporting burden for this collection of information is estimated to average 1 hour per response, including the time for reviewing instructions, searching existing data sources, gathering and maintaining the data needed, and completing and reviewing the collection of information. This agency may not collect this information, and you are not required to complete this form, unless it displays a currently valid OMB control number.

A response is mandatory. Failure to provide any of the information will result in your disapproval for participation in this HUD program.

**U.S. Department of Housing and
Urban Development**
Office of Public and Indian Housing

**Instructions to Bidders for Contracts
Public and Indian Housing Programs**

Instructions to Bidders for Contracts

Public and Indian Housing Programs

Table of Contents

Clause	Page
1. Bid Preparation and Submission	1
2. Explanations and Interpretations to Prospective Bidders	1
3. Amendments to Invitations for Bids	1
4. Responsibility of Prospective Contractor	1
5. Late Submissions, Modifications, and Withdrawal of Bids	1
6. Bid Opening	2
7. Service of Protest	2
8. Contract Award	2
9. Bid Guarantee	3
10. Assurance of Completion	3
11. Preconstruction Conference	3
12. Indian Preference Requirements	3

1. Bid Preparation and Submission

(a) Bidders are expected to examine the specifications, drawings, all instructions, and, if applicable, the construction site (see also the contract clause entitled **Site Investigation and Conditions Affecting the Work** of the *General Conditions of the Contract for Construction*). Failure to do so will be at the bidders' risk.

(b) All bids must be submitted on the forms provided by the Public Housing Agency/Indian Housing Authority (PHA/IHA). Bidders shall furnish all the information required by the solicitation. Bids must be signed and the bidder's name typed or printed on the bid sheet and each continuation sheet which requires the entry of information by the bidder. Erasures or other changes must be initialed by the person signing the bid. Bids signed by an agent shall be accompanied by evidence of that agent's authority. (Bidders should retain a copy of their bid for their records.)

(c) Bidders must submit as part of their bid a completed form HUD-5369-A, "Representations, Certifications, and Other Statements of Bidders."

(d) All bid documents shall be sealed in an envelope which shall be clearly marked with the words "Bid Documents," the Invitation for Bids (IFB) number, any project or other identifying number, the bidder's name, and the date and time for receipt of bids.

(e) If this solicitation requires bidding on all items, failure to do so will disqualify the bid. If bidding on all items is not required, bidders should insert the words "No Bid" in the space provided for any item on which no price is submitted.

(f) Unless expressly authorized elsewhere in this solicitation, alternate bids will not be considered.

(g) Unless expressly authorized elsewhere in this solicitation, bids submitted by telegraph or facsimile (fax) machines will not be considered.

(h) If the proposed contract is for a Mutual Help project (as described in 24 CFR Part 905, Subpart E) that involves Mutual Help contributions of work, material, or equipment, supplemental information regarding the bid advertisement is provided as an attachment to this solicitation.

2. Explanations and Interpretations to Prospective Bidders

(a) Any prospective bidder desiring an explanation or interpretation of the solicitation, specifications, drawings, etc., must request it at least 7 days before the scheduled time for bid opening. Requests may be oral or written. Oral requests must be confirmed in writing. The only oral clarifications that will be provided will be those clearly related to solicitation procedures, i.e., not substantive technical information. No other oral explanation or interpretation will be provided. Any information given a prospective bidder concerning this solicitation will be furnished promptly to all other prospective bidders as a written amendment to the solicitation, if that information is necessary in submitting bids, or if the lack of it would be prejudicial to other prospective bidders.

(b) Any information obtained by, or provided to, a bidder other than by formal amendment to the solicitation shall not constitute a change to the solicitation.

3. Amendments to Invitations for Bids

(a) If this solicitation is amended, then all terms and conditions which are not modified remain unchanged.

(b) Bidders shall acknowledge receipt of any amendment to this solicitation (1) by signing and returning the amendment, (2) by identifying the amendment number and date on the bid form, or (3) by letter, telegram, or facsimile, if those methods are authorized in the solicitation. The PHA/IHA must receive acknowledgement by the time and at the place specified for receipt of bids. Bids which fail to acknowledge the bidder's receipt of any amendment will result in the rejection of the bid if the amendment(s) contained information which substantively changed the PHA's/IHA's requirements.

(c) Amendments will be on file in the offices of the PHA/IHA and the Architect at least 7 days before bid opening.

4. Responsibility of Prospective Contractor

(a) The PHA/IHA will award contracts only to responsible prospective contractors who have the ability to perform successfully under the terms and conditions of the proposed contract. In determining the responsibility of a bidder, the PHA/IHA will consider such matters as the bidder's:

- (1) Integrity;
- (2) Compliance with public policy;
- (3) Record of past performance; and
- (4) Financial and technical resources (including construction and technical equipment).

(b) Before a bid is considered for award, the bidder may be requested by the PHA/IHA to submit a statement or other documentation regarding any of the items in paragraph (a) above. Failure by the bidder to provide such additional information shall render the bidder nonresponsible and ineligible for award.

5. Late Submissions, Modifications, and Withdrawal of Bids

(a) Any bid received at the place designated in the solicitation after the exact time specified for receipt will not be considered unless it is received before award is made and it:

(1) Was sent by registered or certified mail not later than the fifth calendar day before the date specified for receipt of offers (e.g., an offer submitted in response to a solicitation requiring receipt of offers by the 20th of the month must have been mailed by the 15th);

(2) Was sent by mail, or if authorized by the solicitation, was sent by telegram or via facsimile, and it is determined by the PHA/IHA that the late receipt was due solely to mishandling by the PHA/IHA after receipt at the PHA/IHA; or

(3) Was sent by U.S. Postal Service Express Mail Next Day Service - Post Office to Addressee, not later than 5:00 p.m. at the place of mailing two working days prior to the date specified for receipt of proposals. The term "working days" excludes weekends and observed holidays.

(b) Any modification or withdrawal of a bid is subject to the same conditions as in paragraph (a) of this provision.

(c) The only acceptable evidence to establish the date of mailing of a late bid, modification, or withdrawal sent either by registered or certified mail is the U.S. or Canadian Postal Service postmark both on the envelope or wrapper and on the original receipt from the U.S. or Canadian Postal Service. Both postmarks must show a legible date or the bid, modification, or withdrawal shall be processed as if mailed late. "Postmark" means a printed, stamped, or otherwise placed impression (exclusive of a postage meter machine impression) that is readily identifiable without further action as having been supplied and affixed by employees of the U.S. or Canadian Postal Service on the date of mailing. Therefore, bidders should request the postal clerk to place a hand cancellation bull's-eye postmark on both the receipt and the envelope or wrapper.

(d) The only acceptable evidence to establish the time of receipt at the PHA/IHA is the time/date stamp of PHA/IHA on the proposal wrapper or other documentary evidence of receipt maintained by the PHA/IHA.

(e) The only acceptable evidence to establish the date of mailing of a late bid, modification, or withdrawal sent by Express Mail Next Day Service-Post Office to Addressee is the date entered by the post office receiving clerk on the "Express Mail Next Day Service-Post Office to Addressee" label and the postmark on both the envelope or wrapper and on the original receipt from the U.S. Postal Service. "Postmark" has the same meaning as defined in paragraph (c) of this provision, excluding postmarks of the Canadian Postal Service. Therefore, bidders should request the postal clerk to place a legible hand cancellation bull's eye postmark on both the receipt and Failure by a bidder to acknowledge receipt of the envelope or wrapper.

(f) Notwithstanding paragraph (a) of this provision, a late modification of an otherwise successful bid that makes its terms more favorable to the PHA/IHA will be considered at any time it is received and may be accepted.

(g) Bids may be withdrawn by written notice, or if authorized by this solicitation, by telegram (including mailgram) or facsimile machine transmission received at any time before the exact time set for opening of bids; provided that written confirmation of telegraphic or facsimile withdrawals over the signature of the bidder is mailed and postmarked prior to the specified bid opening time. A bid may be withdrawn in person by a bidder or its authorized representative if, before the exact time set for opening of bids, the identity of the person requesting withdrawal is established and the person signs a receipt for the bid.

6. Bid Opening

All bids received by the date and time of receipt specified in the solicitation will be publicly opened and read. The time and place of opening will be as specified in the solicitation. Bidders and other interested persons may be present.

7. Service of Protest

(a) Definitions. As used in this provision:

"Interested party" means an actual or prospective bidder whose direct economic interest would be affected by the award of the contract.

"Protest" means a written objection by an interested party to this solicitation or to a proposed or actual award of a contract pursuant to this solicitation.

(b) Protests shall be served on the Contracting Officer by obtaining written and dated acknowledgement from —

[Contracting Officer designate the official or location where a protest may be served on the Contracting Officer]

(c) All protests shall be resolved in accordance with the PHA's/IHA's protest policy and procedures, copies of which are maintained at the PHA/IHA.

8. Contract Award

(a) The PHA/IHA will evaluate bids in response to this solicitation without discussions and will award a contract to the responsible bidder whose bid, conforming to the solicitation, will be most advantageous to the PHA/IHA considering only price and any price-related factors specified in the solicitation.

(b) If the apparent low bid received in response to this solicitation exceeds the PHA's/IHA's available funding for the proposed contract work, the PHA/IHA may either accept separately priced items (see 8(e) below) or use the following procedure to determine contract award. The PHA/IHA shall apply in turn to each bid (proceeding in order from the apparent low bid to the high bid) each of the separately priced bid deductible items, if any, in their priority order set forth in this solicitation. If upon the application of the first deductible item to all initial bids, a new low bid is within the PHA's/IHA's available funding, then award shall be made to that bidder. If no bid is within the available funding amount, then the PHA/IHA shall apply the second deductible item. The PHA/IHA shall continue this process until an evaluated low bid, if any, is within the PHA's/IHA's available funding. If upon the application of all deductibles, no bid is within the PHA's/IHA's available funding, or if the solicitation does not request separately priced deductibles, the PHA/IHA shall follow its written policy and procedures in making any award under this solicitation.

(c) In the case of tie low bids, award shall be made in accordance with the PHA's/IHA's written policy and procedures.

(d) The PHA/IHA may reject any and all bids, except other than the lowest bid (e.g., the apparent low bid is unreasonably low), and waive informalities or minor irregularities in bids received, in accordance with the PHA's/IHA's written policy and procedures.

(e) Unless precluded elsewhere in the solicitation, the PHA/IHA may accept any item or combination of items bid.

(f) The PHA/IHA may reject any bid as nonresponsive if it is materially unbalanced as to the prices for the various items of work to be performed. A bid is materially unbalanced when it is based on prices significantly less than cost for some work and prices which are significantly overstated for other work.

(g) A written award shall be furnished to the successful bidder within the period for acceptance specified in the bid and shall result in a binding contract without further action by either party.

9. Bid Guarantee (applicable to construction and equipment contracts exceeding \$25,000)

All bids must be accompanied by a negotiable bid guarantee which shall not be less than five percent (5%) of the amount of the bid. The bid guarantee may be a certified check, bank draft, U.S. Government Bonds at par value, or a bid bond secured by a surety company acceptable to the U.S. Government and authorized to do business in the state where the work is to be performed. In the case where the work under the contract will be performed on an Indian reservation area, the bid guarantee may also be an irrevocable Letter of Credit (see provision 10, Assurance of Completion, below). Certified checks and bank drafts must be made payable to the order of the PHA/IHA. The bid guarantee shall insure the execution of the contract and the furnishing of a method of assurance of completion by the successful bidder as required by the solicitation. Failure to submit a bid guarantee with the bid shall result in the rejection of the bid. Bid guarantees submitted by unsuccessful bidders will be returned as soon as practicable after bid opening.

10. Assurance of Completion

(a) Unless otherwise provided in State law, the successful bidder shall furnish an assurance of completion prior to the execution of any contract under this solicitation. This assurance may be [Contracting Officer check applicable items] —

[] (1) a performance and payment bond in a penal sum of 100 percent of the contract price; or, as may be required or permitted by State law;

[] (2) separate performance and payment bonds, each for 50 percent or more of the contract price;

[] (3) a 20 percent cash escrow;

[] (4) a 25 percent irrevocable letter of credit; or,

[] (5) an irrevocable letter of credit for 10 percent of the total contract price with a monitoring and disbursements agreement with the IHA (applicable only to contracts awarded by an IHA under the Indian Housing Program).

(b) Bonds must be obtained from guarantee or surety companies acceptable to the U.S. Government and authorized to do business in the state where the work is to be performed. Individual sureties will not be considered. U.S. Treasury Circular Number 570, published annually in the Federal Register, lists companies approved to act as sureties on bonds securing Government contracts, the maximum underwriting limits on each contract bonded, and the States in which the company is licensed to do business. Use of companies listed in this circular is mandatory. Copies of the circular may be downloaded on the U.S. Department of Treasury website <http://www.fms.treas.gov/c570/index.html>, or ordered for a minimum fee by contacting the Government Printing Office at (202) 512-2168.

(c) Each bond shall clearly state the rate of premium and the total amount of premium charged. The current power of attorney for the person who signs for the surety company must be attached to the bond. The effective date of the power of attorney shall not precede the date of the bond. The effective date of the bond shall be on or after the execution date of the contract.

(d) Failure by the successful bidder to obtain the required assurance of completion within the time specified, or within such extended period as the PHA/IHA may grant based upon reasons determined adequate by the PHA/IHA, shall render the bidder ineligible for award. The PHA/IHA may then either award the contract to the next lowest responsible bidder or solicit new bids. The PHA/IHA may retain the ineligible bidder's bid guarantee.

11. Preconstruction Conference (applicable to construction contracts)

After award of a contract under this solicitation and prior to the start of work, the successful bidder will be required to attend a preconstruction conference with representatives of the PHA/IHA and its architect/engineer, and other interested parties convened by the PHA/IHA. The conference will serve to acquaint the participants with the general plan of the construction operation and all other requirements of the contract (e.g., Equal Employment Opportunity, Labor Standards). The PHA/IHA will provide the successful bidder with the date, time, and place of the conference.

12. Indian Preference Requirements (applicable only if this solicitation is for a contract to be performed on a project for an Indian Housing Authority)

(a) HUD has determined that the contract awarded under this solicitation is subject to the requirements of section 7(b) of the Indian Self-Determination and Education Assistance Act (25 U.S.C. 450e(b)). Section 7(b) requires that any contract or subcontract entered into for the benefit of Indians shall require that, to the greatest extent feasible

(1) Preferences and opportunities for training and employment (other than core crew positions; see paragraph (h) below) in connection with the administration of such contracts or subcontracts be given to qualified "Indians." The Act defines "Indians" to mean persons who are members of an Indian tribe and defines "Indian tribe" to mean any Indian tribe, band, nation, or other organized group or community, including any Alaska Native village or regional or village corporation as defined in or established pursuant to the Alaska Native Claims Settlement Act, which is recognized as eligible for the special programs and services provided by the United States to Indians because of their status as Indians; and,

(2) Preference in the award of contracts or subcontracts in connection with the administration of contracts be given to Indian organizations and to Indian-owned economic enterprises, as defined in section 3 of the Indian Financing Act of 1974 (25 U.S.C. 1452). That Act defines "economic enterprise" to mean any Indian-owned commercial, industrial, or business activity established or organized for the purpose of profit, except that the Indian ownership must constitute not less than 51 percent of the enterprise; "Indian organization" to mean the governing body of any Indian tribe or entity established or recognized by such governing body; "Indian" to mean any person who is a member of any tribe, band, group, pueblo, or community which is recognized by the Federal Government as eligible for services from the Bureau of Indian Affairs and any "Native" as defined in the Alaska Native Claims Settlement Act; and Indian "tribe" to mean any Indian tribe, band, group, pueblo, or community including Native villages and Native groups (including

corporations organized by Kenai, Juneau, Sitka, and Kodiak) as defined in the Alaska Native Claims Settlement Act, which is recognized by the Federal Government as eligible for services from the Bureau of Indian Affairs.

(b) (1) The successful Contractor under this solicitation shall comply with the requirements of this provision in awarding all subcontracts under the contract and in providing training and employment opportunities.

(2) A finding by the IHA that the contractor, either (i) awarded a subcontract without using the procedure required by the IHA, (ii) falsely represented that subcontracts would be awarded to Indian enterprises or organizations; or, (iii) failed to comply with the contractor's employment and training preference bid statement shall be grounds for termination of the contract or for the assessment of penalties or other remedies.

(c) If specified elsewhere in this solicitation, the IHA may restrict the solicitation to qualified Indian-owned enterprises and Indian organizations. If two or more (or a greater number as specified elsewhere in the solicitation) qualified Indian-owned enterprises or organizations submit responsive bids, award shall be made to the qualified enterprise or organization with the lowest responsive bid. If fewer than the minimum required number of qualified Indian-owned enterprises or organizations submit responsive bids, the IHA shall reject all bids and readvertise the solicitation in accordance with paragraph (d) below.

(d) If the IHA prefers not to restrict the solicitation as described in paragraph (c) above, or if after having restricted a solicitation an insufficient number of qualified Indian enterprises or organizations submit bids, the IHA may advertise for bids from non-Indian as well as Indian-owned enterprises and Indian organizations. Award shall be made to the qualified Indian enterprise or organization with the lowest responsive bid if that bid is -

(1) Within the maximum HUD-approved budget amount established for the specific project or activity for which bids are being solicited; and

(2) No more than the percentage specified in 24 CFR 905.175(c) higher than the total bid price of the lowest responsive bid from any qualified bidder. If no responsive bid by a qualified Indian-owned economic enterprise or organization is within the stated range of the total bid price of the lowest responsive bid from any qualified enterprise, award shall be made to the bidder with the lowest bid.

(e) Bidders seeking to qualify for preference in contracting or subcontracting shall submit proof of Indian ownership with their bids. Proof of Indian ownership shall include but not be limited to:

(1) Certification by a tribe or other evidence that the bidder is an Indian. The IHA shall accept the certification of a tribe that an individual is a member.

(2) Evidence such as stock ownership, structure, management, control, financing and salary or profit sharing arrangements of the enterprise.

(f) (1) All bidders must submit with their bids a statement describing how they will provide Indian preference in the award of subcontracts. The specific requirements of that statement and the factors to be used by the IHA in determining the statement's adequacy are included as an attachment to this solicitation. Any bid that fails to include the required statement shall be rejected as nonresponsive. The IHA may require that comparable statements be provided by subcontractors to the successful Contractor, and may require the Contractor to reject any bid or proposal by a subcontractor that fails to include the statement.

(2) Bidders and prospective subcontractors shall submit a certification (supported by credible evidence) to the IHA in any instance where the bidder or subcontractor believes it is infeasible to provide Indian preference in subcontracting. The acceptance or rejection by the IHA of the certification shall be final. Rejection shall disqualify the bid from further consideration.

(g) All bidders must submit with their bids a statement detailing their employment and training opportunities and their plans to provide preference to Indians in implementing the contract; and the number or percentage of Indians anticipated to be employed and trained. Comparable statements from all proposed subcontractors must be submitted. The criteria to be used by the IHA in determining the statement(s)'s adequacy are included as an attachment to this solicitation. Any bid that fails to include the required statement(s), or that includes a statement that does not meet minimum standards required by the IHA shall be rejected as nonresponsive.

(h) Core crew employees. A core crew employee is an individual who is a bona fide employee of the contractor at the time the bid is submitted; or an individual who was not employed by the bidder at the time the bid was submitted, but who is regularly employed by the bidder in a supervisory or other key skilled position when work is available. Bidders shall submit with their bids a list of all core crew employees.

(i) Preference in contracting, subcontracting, employment, and training shall apply not only on-site, on the reservation, or within the IHA's jurisdiction, but also to contracts with firms that operate outside these areas (e.g., employment in modular or manufactured housing construction facilities).

(j) Bidders should contact the IHA to determine if any additional local preference requirements are applicable to this solicitation.

(k) The IHA [] does [] does not [Contracting Officer check applicable box] maintain lists of Indian-owned economic enterprises and Indian organizations by specialty (e.g., plumbing, electrical, foundations), which are available to bidders to assist them in meeting their responsibility to provide preference in connection with the administration of contracts and subcontracts.

**U.S. Department of Housing
and Urban Development**
Office of Public and Indian Housing

**Representations, Certifications,
and Other Statements of Bidders**
Public and Indian Housing Programs

Representations, Certifications, and Other Statements of Bidders

Public and Indian Housing Programs

Table of Contents

Clause	Page
1. Certificate of Independent Price Determination	1
2. Contingent Fee Representation and Agreement	1
3. Certification and Disclosure Regarding Payments to Influence Certain Federal Transactions	1
4. Organizational Conflicts of Interest Certification	2
5. Bidder's Certification of Eligibility	2
6. Minimum Bid Acceptance Period	2
7. Small, Minority, Women-Owned Business Concern Representation	2
8. Indian-Owned Economic Enterprise and Indian Organization Representation	2
9. Certification of Eligibility Under the Davis-Bacon Act	3
10. Certification of Nonsegregated Facilities	3
11. Clean Air and Water Certification	3
12. Previous Participation Certificate	3
13. Bidder's Signature	3

1. Certificate of Independent Price Determination

(a) The bidder certifies that--

(1) The prices in this bid have been arrived at independently, without, for the purpose of restricting competition, any consultation, communication, or agreement with any other bidder or competitor relating to (i) those prices, (ii) the intention to submit a bid, or (iii) the methods or factors used to calculate the prices offered;

(2) The prices in this bid have not been and will not be knowingly disclosed by the bidder, directly or indirectly, to any other bidder or competitor before bid opening (in the case of a sealed bid solicitation) or contract award (in the case of a competitive proposal solicitation) unless otherwise required by law; and

(3) No attempt has been made or will be made by the bidder to induce any other concern to submit or not to submit a bid for the purpose of restricting competition.

(b) Each signature on the bid is considered to be a certification by the signatory that the signatory--

(1) Is the person in the bidder's organization responsible for determining the prices being offered in this bid or proposal, and that the signatory has not participated and will not participate in any action contrary to subparagraphs (a)(1) through (a)(3) above; or

(2) (i) Has been authorized, in writing, to act as agent for the following principals in certifying that those principals have not participated, and will not participate in any action contrary to subparagraphs (a)(1) through (a)(3) above.

_____ [insert full name of person(s) in the bidder's organization responsible for determining the prices offered in this bid or proposal, and the title of his or her position in the bidder's organization];

(ii) As an authorized agent, does certify that the principals named in subdivision (b)(2)(i) above have not participated, and will not participate, in any action contrary to subparagraphs (a)(1) through (a)(3) above; and

(iii) As an agent, has not personally participated, and will not participate in any action contrary to subparagraphs (a)(1) through (a)(3) above.

(c) If the bidder deletes or modifies subparagraph (a)2 above, the bidder must furnish with its bid a signed statement setting forth in detail the circumstances of the disclosure.

[] [Contracting Officer check if following paragraph is applicable]

(d) Non-collusive affidavit. (applicable to contracts for construction and equipment exceeding \$50,000)

(1) Each bidder shall execute, in the form provided by the PHA/IHA, an affidavit to the effect that he/she has not colluded with any other person, firm or corporation in regard to any bid submitted in response to this solicitation. If the successful bidder did not submit the affidavit with his/her bid, he/she must submit it within three (3) working days of bid opening. Failure to submit the affidavit by that date may render the bid nonresponsive. No contract award will be made without a properly executed affidavit.

(2) A fully executed "Non-collusive Affidavit" [] is, [] is not included with the bid.

2. Contingent Fee Representation and Agreement

(a) Definitions. As used in this provision:

"Bona fide employee" means a person, employed by a bidder and subject to the bidder's supervision and control as to time, place, and manner of performance, who neither exerts, nor proposes to exert improper influence to solicit or obtain contracts nor holds out as being able to obtain any contract(s) through improper influence.

"Improper influence" means any influence that induces or tends to induce a PHA/IHA employee or officer to give consideration or to act regarding a PHA/IHA contract on any basis other than the merits of the matter.

(b) The bidder represents and certifies as part of its bid that, except for full-time bona fide employees working solely for the bidder, the bidder:

(1) [] has, [] has not employed or retained any person or company to solicit or obtain this contract; and

(2) [] has, [] has not paid or agreed to pay to any person or company employed or retained to solicit or obtain this contract any commission, percentage, brokerage, or other fee contingent upon or resulting from the award of this contract.

(c) If the answer to either (a)(1) or (a)(2) above is affirmative, the bidder shall make an immediate and full written disclosure to the PHA/IHA Contracting Officer.

(d) Any misrepresentation by the bidder shall give the PHA/IHA the right to (1) terminate the contract; (2) at its discretion, deduct from contract payments the amount of any commission, percentage, brokerage, or other contingent fee; or (3) take other remedy pursuant to the contract.

3. Certification and Disclosure Regarding Payments to Influence Certain Federal Transactions (applicable to contracts exceeding \$100,000)

(a) The definitions and prohibitions contained in Section 1352 of title 31, United States Code, are hereby incorporated by reference in paragraph (b) of this certification.

(b) The bidder, by signing its bid, hereby certifies to the best of his or her knowledge and belief as of December 23, 1989 that:

(1) No Federal appropriated funds have been paid or will be paid to any person for influencing or attempting to influence an officer or employee of any agency, a Member of Congress, an officer or employee of Congress, or an employee of a Member of Congress on his or her behalf in connection with the awarding of a contract resulting from this solicitation;

(2) If any funds other than Federal appropriated funds (including profit or fee received under a covered Federal transaction) have been paid, or will be paid, to any person for influencing or attempting to influence an officer or employee of any agency, a Member of Congress, an officer or employee of Congress, or an employee of a Member of Congress on his or her behalf in connection with this solicitation, the bidder shall complete and submit, with its bid, OMB standard form LLL, "Disclosure of Lobbying Activities;" and

(3) He or she will include the language of this certification in all subcontracts at any tier and require that all recipients of subcontract awards in excess of \$100,000 shall certify and disclose accordingly.

(c) Submission of this certification and disclosure is a prerequisite for making or entering into this contract imposed by section 1352, title 31, United States Code. Any person who makes an expenditure prohibited under this provision or who fails to file or amend the disclosure form to be filed or amended by this provision, shall be subject to a civil penalty of not less than \$10,000, and not more than \$100,000, for each such failure.

(d) Indian tribes (except those chartered by States) and Indian organizations as defined in section 4 of the Indian Self-Determination and Education Assistance Act (25 U.S.C. 450B) are exempt from the requirements of this provision.

4. Organizational Conflicts of Interest Certification

The bidder certifies that to the best of its knowledge and belief and except as otherwise disclosed, he or she does not have any organizational conflict of interest which is defined as a situation in which the nature of work to be performed under this proposed contract and the bidder's organizational, financial, contractual, or other interests may, without some restriction on future activities:

- (a) Result in an unfair competitive advantage to the bidder; or,
- (b) Impair the bidder's objectivity in performing the contract work.

[] In the absence of any actual or apparent conflict, I hereby certify that to the best of my knowledge and belief, no actual or apparent conflict of interest exists with regard to my possible performance of this procurement.

5. Bidder's Certification of Eligibility

(a) By the submission of this bid, the bidder certifies that to the best of its knowledge and belief, neither it, nor any person or firm which has an interest in the bidder's firm, nor any of the bidder's subcontractors, is ineligible to:

(1) Be awarded contracts by any agency of the United States Government, HUD, or the State in which this contract is to be performed; or,

(2) Participate in HUD programs pursuant to 24 CFR Part 24.

(b) The certification in paragraph (a) above is a material representation of fact upon which reliance was placed when making award. If it is later determined that the bidder knowingly rendered an erroneous certification, the contract may be terminated for default, and the bidder may be debarred or suspended from participation in HUD programs and other Federal contract programs.

6. Minimum Bid Acceptance Period

(a) "Acceptance period," as used in this provision, means the number of calendar days available to the PHA/IHA for awarding a contract from the date specified in this solicitation for receipt of bids.

(b) This provision supersedes any language pertaining to the acceptance period that may appear elsewhere in this solicitation.

(c) The PHA/IHA requires a minimum acceptance period of [Contracting Officer insert time period] calendar days.

(d) In the space provided immediately below, bidders may specify a longer acceptance period than the PHA's/IHA's minimum requirement. The bidder allows the following acceptance period: calendar days.

(e) A bid allowing less than the PHA's/IHA's minimum acceptance period will be rejected.

(f) The bidder agrees to execute all that it has undertaken to do, in compliance with its bid, if that bid is accepted in writing within (1) the acceptance period stated in paragraph (c) above or (2) any longer acceptance period stated in paragraph (d) above.

7. Small, Minority, Women-Owned Business Concern Representation

The bidder represents and certifies as part of its bid/ offer that it --

(a) [] is, [] is not a small business concern. "Small business concern," as used in this provision, means a concern, including its affiliates, that is independently owned and operated, not dominant in the field of operation in which it is bidding, and qualified as a small business under the criteria and size standards in 13 CFR 121.

(b) [] is, [] is not a women-owned business enterprise. "Women-owned business enterprise," as used in this provision, means a business that is at least 51 percent owned by a woman or women who are U.S. citizens and who also control and operate the business.

(c) [] is, [] is not a minority business enterprise. "Minority business enterprise," as used in this provision, means a business which is at least 51 percent owned or controlled by one or more minority group members or, in the case of a publicly owned business, at least 51 percent of its voting stock is owned by one or more minority group members, and whose management and daily operations are controlled by one or more such individuals. For the purpose of this definition, minority group members are:

(Check the block applicable to you)

- | | |
|------------------------|------------------------------|
| [] Black Americans | [] Asian Pacific Americans |
| [] Hispanic Americans | [] Asian Indian Americans |
| [] Native Americans | [] Hasidic Jewish Americans |

8. Indian-Owned Economic Enterprise and Indian Organization Representation (applicable only if this solicitation is for a contract to be performed on a project for an Indian Housing Authority)

The bidder represents and certifies that it:

(a) [] is, [] is not an Indian-owned economic enterprise. "Economic enterprise," as used in this provision, means any commercial, industrial, or business activity established or organized for the purpose of profit, which is at least 51 percent Indian owned. "Indian," as used in this provision, means any person who is a member of any tribe, band, group, pueblo, or community which is recognized by the Federal Government as eligible for services from the Bureau of Indian Affairs and any "Native" as defined in the Alaska Native Claims Settlement Act.

(b) [] is, [] is not an Indian organization. "Indian organization," as used in this provision, means the governing body of any Indian tribe or entity established or recognized by such governing body. Indian "tribe" means any Indian tribe, band, group, pueblo, or

community including Native villages and Native groups (including corporations organized by Kenai, Juneau, Sitka, and Kodiak) as defined in the Alaska Native Claims Settlement Act, which is recognized by the Federal Government as eligible for services from the Bureau of Indian Affairs.

9. Certification of Eligibility Under the Davis-Bacon Act (applicable to construction contracts exceeding \$2,000)

(a) By the submission of this bid, the bidder certifies that neither it nor any person or firm who has an interest in the bidder's firm is a person or firm ineligible to be awarded contracts by the United States Government by virtue of section 3(a) of the Davis-Bacon Act or 29 CFR 5.12(a)(1).

(b) No part of the contract resulting from this solicitation shall be subcontracted to any person or firm ineligible to be awarded contracts by the United States Government by virtue of section 3(a) of the Davis-Bacon Act or 29 CFR 5.12(a)(1).

(c) The penalty for making false statements is prescribed in the U. S. Criminal Code, 18 U.S.C. 1001.

10. Certification of Nonsegregated Facilities (applicable to contracts exceeding \$10,000)

(a) The bidder's attention is called to the clause entitled **Equal Employment Opportunity** of the General Conditions of the Contract for Construction.

(b) "Segregated facilities," as used in this provision, means any waiting rooms, work areas, rest rooms and wash rooms, restaurants and other eating areas, time clocks, locker rooms and other storage or dressing areas, parking lots, drinking fountains, recreation or entertainment areas, transportation, and housing facilities provided for employees, that are segregated by explicit directive or are in fact segregated on the basis of race, color, religion, or national origin because of habit, local custom, or otherwise.

(c) By the submission of this bid, the bidder certifies that it does not and will not maintain or provide for its employees any segregated facilities at any of its establishments, and that it does not and will not permit its employees to perform their services at any location under its control where segregated facilities are maintained. The bidder agrees that a breach of this certification is a violation of the Equal Employment Opportunity clause in the contract.

(d) The bidder further agrees that (except where it has obtained identical certifications from proposed subcontractors for specific time periods) prior to entering into subcontracts which exceed \$10,000 and are not exempt from the requirements of the Equal Employment Opportunity clause, it will:

- (1) Obtain identical certifications from the proposed subcontractors;
- (2) Retain the certifications in its files; and
- (3) Forward the following notice to the proposed subcontractors (except if the proposed subcontractors have submitted identical certifications for specific time periods):

Notice to Prospective Subcontractors of Requirement for Certifications of Nonsegregated Facilities

A Certification of Nonsegregated Facilities must be submitted before the award of a subcontract exceeding \$10,000 which is not exempt from the provisions of the Equal Employment Opportunity clause of the prime contract. The certification may be submitted either for each subcontract or for all subcontracts during a period (i.e., quarterly, semiannually, or annually).

Note: The penalty for making false statements in bids is prescribed in 18 U.S.C. 1001.

11. Clean Air and Water Certification (applicable to contracts exceeding \$100,000)

The bidder certifies that:

(a) Any facility to be used in the performance of this contract [] is, [] is not listed on the Environmental Protection Agency List of Violating Facilities:

(b) The bidder will immediately notify the PHA/IHA Contracting Officer, before award, of the receipt of any communication from the Administrator, or a designee, of the Environmental Protection Agency, indicating that any facility that the bidder proposes to use for the performance of the contract is under consideration to be listed on the EPA List of Violating Facilities; and,

(c) The bidder will include a certification substantially the same as this certification, including this paragraph (c), in every nonexempt subcontract.

12. Previous Participation Certificate (applicable to construction and equipment contracts exceeding \$50,000)

(a) The bidder shall complete and submit with his/her bid the Form HUD-2530, "Previous Participation Certificate." If the successful bidder does not submit the certificate with his/her bid, he/she must submit it within three (3) working days of bid opening. Failure to submit the certificate by that date may render the bid nonresponsive. No contract award will be made without a properly executed certificate.

(b) A fully executed "Previous Participation Certificate" [] is, [] is not included with the bid.

13. Bidder's Signature

The bidder hereby certifies that the information contained in these certifications and representations is accurate, complete, and current.

(Signature and Date)

(Typed or Printed Name)

(Title)

(Company Name)

(Company Address)

FORM OF NON-COLLUSIVE AFFIDAVIT

A F F I D A V I T

(Firm Submitting Proposal)

State of _____) ss

Country of _____)

_____, being first duly sworn, deposes
and says:

That he is _____ (A partner or officer of the firm of, etc.)
the party making the foregoing proposal, that such proposal is genuine and not collusive or sham; that
said person has not colluded, conspired connived or agreed, directly or indirectly with any person, to put
in a sham proposal or to refrain from submitting a proposal, and has not in any manner, directly or
indirectly, sought by agreement or collusion, or communication or conference, with any person, to fix the
proposal price or affidavit or any other firm submitting a proposal, or to fix any overhead, profit or cost
element of said proposal price. or of that of any other firm submitting a proposal, or to secure any
advantage against the _____ (LHA) _____ or any person interested in the
proposed contract; and that all statements in said proposal are true.

Signature of:

Authorized Individual if Proposal is

Submitted as an Individual. Partnership.

Corporation, etc.

Subscribed and sworn to before me

this _____ day of _____, 20____

My commission expires _____, 20____.

Section 3 Clause

A. The work to be performed under this contract is subject to the requirements of section 3 of the Housing and Urban Development Act of 1968, as amended, 12 U.S.C. 1701u (Section 3). The purpose of Section 3 is to ensure that employment and other economic opportunities generated by HUD assistance or HUD-assisted projects covered by Section 3, shall, to the greatest extent feasible, be directed to low- and very low-income persons, particularly persons who are recipients of HUD assistance for housing.

B. The parties to this contract agree to comply with HUD's regulations in 24 CFR part 135, which implement Section 3. As evidenced by their execution of this contract, the parties to this contract certify that they are under no contractual or other impediment that would prevent them from complying with the part 135 regulations.

C. The contractor agrees to send to each labor organization or representative or workers with which the contractor has a collective bargaining agreement or other understanding, if any, a notice advising the labor organization or workers' representative of the contractor's commitments under this Section 3 clause, and will post copies of the notice in conspicuous places at the work site where both employees and applicants for training and employment positions can see the notice. The notice shall describe the Section 3 preference, shall set forth minimum number and job titles subject to hire, availability of apprenticeship and training positions, the qualifications for each; and the name and location of the person(s) taking applications for each of the positions; and the anticipated date the work shall begin.

D. The contractor agrees to include this Section 3 clause in every subcontract subject to compliance with regulations in 24 CFR part 135, and agrees to take appropriate action, as provided in an applicable provision of the subcontract or in this Section 3 clause, upon a finding that the subcontractor is in violation of the regulations in 24 CFR part 135. The contractor will not subcontract with any subcontractor where the contractor has notice or knowledge that the subcontractor has been found in violation of the regulations in 24 CFR part 135.

E. The contractor will certify that any vacant employment positions, including training positions, that are filled (1) after the contractor is selected but before the contract is executed, and (2) with persons other than those to whom the regulations of 24 CFR part 135 require employment opportunities to be directed, were not filled to circumvent the contractor's obligations under 24 CFR part 135.

F. Noncompliance with HUD's regulations in 24 CFR part 135 may result in sanctions, termination of this contract for default, and debarment or suspension from future HUD assisted contracts.

G. With respect to work performed in connection with Section 3 covered Indian housing assistance, section 7(b) of the Indian Self-Determination and Education Assistance Act (25 U.S.C. 450e) also applies to the work to be performed under this contract. Section 7(b) requires that to the greatest extent feasible (i) preference and opportunities for training and employment shall be given to Indians, and (ii) preference in the award of contracts and subcontracts shall be given to Indian organizations and Indian-owned Economic Enterprises. Parties to this contract that are subject to the provisions of Section 3 to the maximum extent feasible, but not in derogation of compliance with section 7(b).

Record of Employee Interview Instructions

U.S. Department of Housing
and Urban Development
Office of Labor Relations

OMB Approval No. 2501-0009
(exp. 10/31/2010)

Instructions

General:

This form is to be used by HUD and local agency staff for recording information gathered during on-site interviews with laborers and mechanics employed on projects subject to Federal prevailing wage requirements. Typically, the staff that will conduct on-site interviews and use this form are HUD staff and fee construction inspectors, HUD Labor Relations staff, and local agency labor standards contract monitors.

Information recorded on the form HUD-11 is evaluated for general compliance and compared to certified payroll reports submitted by the respective employer. The comparison tests the veracity of the payroll reports and may be critical to the successful conclusion of enforcement actions in the event of labor standards violations. The thoroughness and accuracy of the information gathered during interviews is crucial.

Note that the interview itself and the information collected on the form HUD-11 are considered confidential. Interviews should be conducted individually and privately. All laborers and mechanics employed on the job site must be made available for interview at the interviewer's request. The employee's participation, however, is voluntary. Interviews shall be conducted in a manner and place that are conducive to the purposes of the interview and that cause the least inconvenience to the employer(s) and the employee(s).

Completing the form HUD-11

Items 1a - 1c: Self-explanatory

Items 2a – 2d: Enter the employee's full name, a telephone number where the employee can be reached, and the employee's home address. Many construction workers use a temporary address in the locality of the project and have a more permanent address elsewhere from which mail may be forwarded to them. Obtain a more permanent address, if available. Ask the employee for a form of identification (e.g., driver's license) to verify their name.

Items 3a – 4c: Enter the employee's responses. Ask the employee whether they have a pay stub with them; if so, determine whether the pay stub is consistent with the information provided by the employee.

Items 5 – 7: Be certain that the employee's responses are specific. For example, job classification (#5) must identify the trade involved (e.g., Carpenter, Electrician, Plumber) – responses such as "journeyman" or "mechanic" are not helpful for our purposes.

Items 8 – 12b: Self-explanatory

Items 13 – 15c: These items represent some of the most important information that can be gathered while conducting on-site interviews. Please be specific about the duties you observed the employee performing. It may be easiest to make these observations before initiating the interview. Please record any comments or remarks that may be helpful. For example, if the employee interviewed was working with a crew, how many workers were in the crew? Was the employee evasive?

The level of specificity that is warranted is directly related to the extent to which interview(s) or other observations indicate that there may be violations present. If interviews indicate that there may be underpayments involving a particular trade(s), the interviewer is encouraged to interview as many workers in that trade(s) that are available.

Items 16 – 17b: The information on the form HUD-11 may be reviewed for general compliance, initially. For example, are the job classification and wage rate stated by the employee compatible with the classifications and wage rates on the applicable wage decision? Are the duties observed by the interviewer consistent with the job classification?

Once the corresponding certified payroll reports are received, the information on the HUD-11 shall be compared to the payroll reports. Any discrepancies noted between the HUD-11 information and that on the payroll report shall be noted in Item 16, Remarks. If discrepancies are noted, follow-up actions to resolve the discrepancies must be taken.

Record of Employee Interview

U.S. Department of Housing and Urban Development Office of Labor Relations

OMB Approval No. 2501-0009
(exp. 10/31/2010)

Public reporting burden for this collection of information is estimated to average 15 minutes per response, including the time for reviewing instructions, searching existing data sources, gathering and maintaining the data needed, and completing and reviewing the collection of information. This agency may not collect this information, and you are not required to complete this form, unless it displays a currently valid OMB control number. The information is collected to ensure compliance with the Federal labor standards by recording interviews with construction workers. The information collected will assist HUD in the conduct of compliance monitoring; the information will be used to test the veracity of certified payroll reports submitted by the employer. **Sensitive Information.** The information collected on this form is considered sensitive and is protected by the Privacy Act. The Privacy Act requires that these records be maintained with appropriate administrative, technical, and physical safeguards to ensure their security and confidentiality. In addition, these records should be protected against any anticipated threats or hazards to their security or integrity that could result in substantial harm, embarrassment, inconvenience, or unfairness to any individual on whom the information is maintained. **The information collected herein is voluntary, and any information provided shall be kept confidential.**

1a. Project Name			2a. Employee Name		
1b. Project Number			2b. Employee Phone Number (including area code)		
1c. Contractor or Subcontractor (Employer)			2c. Employee Home Address & Zip Code		
			2d. Verification of identification? Yes <input type="checkbox"/> No <input type="checkbox"/>		
3a. How long on this job?	3b. Last date on this job before today?	3c. No. of hours last day on this job?	4a. Hourly rate of pay?	4b. Fringe Benefits?	4c. Pay stub?
				Vacation Yes <input type="checkbox"/> No <input type="checkbox"/> Medical Yes <input type="checkbox"/> No <input type="checkbox"/> Pension Yes <input type="checkbox"/> No <input type="checkbox"/>	Yes <input type="checkbox"/> No <input type="checkbox"/>

5. Your job classification(s) (list all) --- continue on a separate sheet if necessary

6. Your duties

7. Tools or equipment used

	Y	N		Y	N
8. Are you an apprentice or trainee?	<input type="checkbox"/>	<input type="checkbox"/>	10. Are you paid at least time and 1/2 for all hours worked in excess of 40 in a week?	<input type="checkbox"/>	<input type="checkbox"/>
9. Are you paid for all hours worked?	<input type="checkbox"/>	<input type="checkbox"/>	11. Have you ever been threatened or coerced into giving up any part of your pay?	<input type="checkbox"/>	<input type="checkbox"/>

12a. Employee Signature	12b. Date
-------------------------	-----------

13. Duties observed by the Interviewer (Please be specific.)

14. Remarks

15a. Interviewer name (please print)	15b. Signature of Interviewer	15c. Date of interview
--------------------------------------	-------------------------------	------------------------

Payroll Examination

16. Remarks

17a. Signature of Payroll Examiner	17b. Date
------------------------------------	-----------

Date: _____

Contractor: _____

Re: Contractual Liability Risk Management

It is our policy to identify and effectively manage our contractual liabilities arising out of business relationships with Contractors. We seek to take responsibility for our own actions and their consequences, while requiring our business partners to assume a share of risk relative to their ability to control it.

Given the number of contractual relationships that we may have at any point in time, it is imperative that we control the type and magnitude of the liabilities we assume. Conversely, we will look for opportunities to ensure that where legally possible, we manage our risks by asking others to contractually assume their share of liability. The effective management of these liabilities will allow us to lower our overall cost of risk. This program is a vital element of our overall safety and risk management program.

In order to perform as a Contractor for us, we will require a certificate of insurance form from you with limits equal to or greater than those on the attached sample certificate. We will require that we have additional insured coverage on your general liability policy for ongoing and completed operation on a primary and non-contributory basis as indicated on the attached sample certificate.

The following Hold Harmless and Indemnity Agreement, as evidenced by your (the Contractors') signature below, hereby applies to all work performed by the Contractor on our behalf, whether or not a separate work order or contract has been signed or agreed to between the parties:

To the fullest extent permitted by law, the Contractor hereby acknowledges and agrees that it shall indemnify, hold harmless and defend **The Housing Authority of the City of Pawtucket** and any of their officers, directors, employees, agents, affiliates, subsidiaries and partners, from and against all claims, damages, losses and expenses, including but not limited to, attorney's fees,

Paula McFarland, Executive Director
Mary E. Bray, Commissioner

Adrienne J. Kirschner, Commissioner

Beth Roberge, Chairperson
Robert Ricci, Commissioner

Kevin Rabbitt, Commissioner

George L. Kelley, III, Vice Chairperson
Olga Torres, Commissioner

arising out of or resulting from the performance of the Contractor's work, provided that any such claim, damage, loss or expense (1) is attributable to bodily injury, sickness, disease or death or to the destruction of tangible property (other than to the work itself) including loss of use resulting there from, and (2) is caused in whole or in part by any acts or omissions of the Contractor, its employees, agents or Subcontractors or anyone directly or indirectly employed by any of them, or anyone whose acts any of them may be liable.

The Contractor hereby acknowledges its obligation under the foregoing paragraph to indemnify **The Housing Authority of the City of Pawtucket** against judgments suffered because of the Contractor's work and to assume the cost of defending **The Housing Authority of the City of Pawtucket** against claims as described in the foregoing paragraph.

Name:

Title:

Company:

We must receive the required Certificate of Insurance meeting all of our requirements, as well as the Contractors signature above accepting the terms of this letter, prior to the beginning of any work.

If you have any questions on the above requirements, please contact **Joseph Loconto** at **(401) 721-6013**.

Sincerely,

The Housing Authority of the City of Pawtucket



By: **Paula McFarland**

Title: **Executive Director**



CERTIFICATE OF LIABILITY INSURANCE

DATE (MM/DD/YYYY)

Current Date

THIS CERTIFICATE IS ISSUED AS A MATTER OF INFORMATION ONLY AND CONFERS NO RIGHTS UPON THE CERTIFICATE HOLDER. THIS CERTIFICATE DOES NOT AFFIRMATIVELY OR NEGATIVELY AMEND, EXTEND OR ALTER THE COVERAGE AFFORDED BY THE POLICIES BELOW. THIS CERTIFICATE OF INSURANCE DOES NOT CONSTITUTE A CONTRACT BETWEEN THE ISSUING INSURER(S), AUTHORIZED REPRESENTATIVE OR PRODUCER, AND THE CERTIFICATE HOLDER.

IMPORTANT: If the certificate holder is an **ADDITIONAL INSURED**, the policy(ies) must have **ADDITIONAL INSURED** provisions or be endorsed. If **SUBROGATION IS WAIVED**, subject to the terms and conditions of the policy, certain policies may require an endorsement. A statement on this certificate does not confer rights to the certificate holder in lieu of such endorsement(s).

PRODUCER Contractor Insurance Agent 123 Main Street Anytown State Zip	CONTACT NAME:	
	PHONE (A/C, No, Ext):	FAX (A/C, No):
INSURED Contractor Name Address City State Zip	E-MAIL ADDRESS:	
	INSURER(S) AFFORDING COVERAGE	
	INSURER A:	ABC Insurance Company
	INSURER B:	DEF Insurance Company
	INSURER C:	GHI Insurance Company
	INSURER D:	
	INSURER E:	
	INSURER F:	

COVERAGES

CERTIFICATE NUMBER:

REVISION NUMBER:

THIS IS TO CERTIFY THAT THE POLICIES OF INSURANCE LISTED BELOW HAVE BEEN ISSUED TO THE INSURED NAMED ABOVE FOR THE POLICY PERIOD INDICATED. NOTWITHSTANDING ANY REQUIREMENT, TERM OR CONDITION OF ANY CONTRACT OR OTHER DOCUMENT WITH RESPECT TO WHICH THIS CERTIFICATE MAY BE ISSUED OR MAY PERTAIN, THE INSURANCE AFFORDED BY THE POLICIES DESCRIBED HEREIN IS SUBJECT TO ALL THE TERMS, EXCLUSIONS AND CONDITIONS OF SUCH POLICIES. LIMITS SHOWN MAY HAVE BEEN REDUCED BY PAID CLAIMS.

INSR LTR	TYPE OF INSURANCE	ADDL INSD	SUBR WVD	POLICY NUMBER	POLICY EFF (MM/DD/YYYY)	POLICY EXP (MM/DD/YYYY)	LIMITS
A	<input checked="" type="checkbox"/> COMMERCIAL GENERAL LIABILITY <input type="checkbox"/> CLAIMS-MADE <input checked="" type="checkbox"/> OCCUR GEN'L AGGREGATE LIMIT APPLIES PER: <input type="checkbox"/> POLICY <input type="checkbox"/> PROJECT <input type="checkbox"/> LOC OTHER:	X	X	Policy Number	Current	Date	EACH OCCURRENCE \$ 1,000,000 DAMAGE TO RENTED PREMISES (Ea occurrence) \$ 100,000 MED EXP (Any one person) \$ 5,000 PERSONAL & ADV INJURY \$ 1,000,000 GENERAL AGGREGATE \$ 2,000,000 PRODUCTS - COMP/OP AGG \$ 2,000,000 \$
B	AUTOMOBILE LIABILITY <input checked="" type="checkbox"/> ANY AUTO <input type="checkbox"/> OWNED AUTOS ONLY <input type="checkbox"/> SCHEDULED AUTOS <input checked="" type="checkbox"/> HIRED AUTOS ONLY <input checked="" type="checkbox"/> NON-OWNED AUTOS ONLY	X	X	Policy Number	Current	Date	COMBINED SINGLE LIMIT (Ea accident) \$ 1,000,000 BODILY INJURY (Per person) \$ BODILY INJURY (Per accident) \$ PROPERTY DAMAGE (Per accident) \$ \$
A	<input checked="" type="checkbox"/> UMBRELLA LIAB <input checked="" type="checkbox"/> OCCUR <input type="checkbox"/> EXCESS LIAB <input type="checkbox"/> CLAIMS-MADE DED RETENTION \$						EACH OCCURRENCE \$ 1,000,000 AGGREGATE \$ 1,000,000 \$
C	WORKERS COMPENSATION AND EMPLOYERS' LIABILITY ANY PROPRIETOR/PARTNER/EXECUTIVE OFFICER/MEMBER EXCLUDED? (Mandatory in NH) If yes, describe under DESCRIPTION OF OPERATIONS below			Policy Number	Current	Date	<input checked="" type="checkbox"/> PER STATUTE <input type="checkbox"/> OTHER E.L. EACH ACCIDENT \$ 500,000 E.L. DISEASE - EA EMPLOYEE \$ 500,000 E.L. DISEASE - POLICY LIMIT \$ 500,000

DESCRIPTION OF OPERATIONS / LOCATIONS / VEHICLES (ACORD 101, Additional Remarks Schedule, may be attached if more space is required)

The certificate holder is included as an additional insured on the general liability policy for both ongoing (CG2010) and completed (CG20137) operations, or their equivalents, on a primary and non-contributory basis. All insurance carriers affording coverage are admitted to do business in the State of Rhode Island.

CERTIFICATE HOLDER

CANCELLATION

The Housing Authority of the City of Pawtucket RI 214 Roosevelt Avenue Pawtucket RI 02862-1303	SHOULD ANY OF THE ABOVE DESCRIBED POLICIES BE CANCELLED BEFORE THE EXPIRATION DATE THEREOF, NOTICE WILL BE DELIVERED IN ACCORDANCE WITH THE POLICY PROVISIONS.
	AUTHORIZED REPRESENTATIVE <input checked="" type="checkbox"/> Must be signed

© 1988-2015 ACORD CORPORATION. All rights reserved.

Pawtucket Housing Authority

2021 Holiday Schedule

<u>Day</u>	<u>Date</u>	<u>Holiday</u>
Friday	01/01/2021	New Year's Day
Monday	01/18/2021	Martin Luther King
Monday	02/15/2021	President's Day
Monday	05/31/2021	Memorial Day
Monday	07/05/2021	Independence Day
Monday	08/9/2021	Victory Day
Monday	09/06/2021	Labor Day
Monday	10/11/2021	Columbus Day
Thursday	11/11/2021	Veteran's Day
Wednesday	11/24/2021	Thanksgiving Eve - 1/2 Day
Thursday	11/25/2021	Thanksgiving Day
Friday	11/26/2021	Day after Thanksgiving
Thursday	12/23/2021	Christmas Eve - 1/2 Day
Friday	12/24/2021	Christmas Day
Thursday	12/30/2021	New Year's Eve - 1/2 Day
Friday	12/31/2021	New Year's Day

PREVAILING WAGE RATES

*Pawtucket Housing Authority
St. Germain Manor Deck Improvements
Pawtucket, Rhode Island*

Prevailing Wage Rates - 1

PREVAILING WAGE RATES

Attention of the bidders is particularly called to the requirements as to conditions of employment to be observed and minimum wage rates to be paid under the Contract. The minimum wages for a day's work paid to craftsmen, and laborers shall be not less than the customary and prevailing rate of wages for a day's work in the locality where the work is undertaken. Such a schedule of wages has been established on a minimum hourly basis and is on file in the office of the State Department of Labor

The State of Rhode Island Department of Labor, Division of Professional Regulation General Decision Modification document current as of the bid posting date for this Project, is an integral part of the Bid Documents for use in fulfilling prevailing wage rate requirements. A copy is available on the web site of the State of Rhode Island Department of Labor & Training website.

The Department of Labor & Training Website:

<http://www.dlt.ri.gov>

END OF DOCUMENT

"General Decision Number: RI20210002 06/18/2021

Superseded General Decision Number: RI20200002

State: Rhode Island

Construction Type: Residential

Counties: Bristol, Kent, Providence and Washington Counties in Rhode Island.

RESIDENTIAL CONSTRUCTION PROJECTS (consisting of single family homes and apartments up to and including 4 stories)

Note: Under Executive Order (EO) 13658, an hourly minimum wage of \$10.95 for calendar year 2021 applies to all contracts subject to the Davis-Bacon Act for which the contract is awarded (and any solicitation was issued) on or after January 1, 2015. If this contract is covered by the EO, the contractor must pay all workers in any classification listed on this wage determination at least \$10.95 per hour (or the applicable wage rate listed on this wage determination, if it is higher) for all hours spent performing on the contract in calendar year 2021. If this contract is covered by the EO and a classification considered necessary for performance of work on the contract does not appear on this wage determination, the contractor must pay workers in that classification at least the wage rate determined through the conformance process set forth in 29 CFR 5.5(a)(1)(ii) (or the EO minimum wage rate, if it is higher than the conformed wage rate). The EO minimum wage rate will be adjusted annually. Please note that this EO applies to the above-mentioned types of contracts entered into by the federal government that are subject to the Davis-Bacon Act itself, but it does not apply to contracts subject only to the Davis-Bacon Related Acts, including those set forth at 29 CFR 5.1(a)(2)-(60). Additional information on contractor requirements and worker protections under the EO is available at www.dol.gov/whd/govcontracts.

Modification Number	Publication Date
0	01/01/2021
1	01/22/2021
2	03/05/2021
3	06/18/2021

ASBE0006-009 09/01/2019

Rates Fringes

INSULATOR - PIPE & PIPEWRAPPER Includes application of all insulating materials, protective coverings, coatings & finishes to all types of mechanical systems.	\$ 43.60	29.90
---	----------	-------

* ELEC0099-004 06/01/2021

Rates Fringes

ELECTRICIAN.....	\$ 32.71	6.09%+15.22
------------------	----------	-------------

FOOTNOTE: Work of a hazardous nature, or where the work height is 30 feet or more from the floor, except when working OSHA-approved lifts: 20% per hour additional.

ELEV0039-002 01/01/2021

	Rates	Fringes
ELEVATOR MECHANIC.....	\$ 55.03	35.825+A+B

FOOTNOTES:

A. PAID HOLIDAYS: New Years Day; Memorial Day; Independence Day; Labor Day; Veterans' Day; Thanksgiving Day; the Friday after Thanksgiving Day; and Christmas Day.

B. Employer contributes 8% basic hourly rate for 5 years or more of service or 6% basic hourly rate for 6 months to 5 years of service as vacation pay credit.

ENGI0057-004 12/01/2020

	Rates	Fringes
Power Equipment Operator		
Grader and Roller.....	\$ 38.90	27.70+a
Paver.....	\$ 39.82	27.70+a

a. FOOTNOTES: Any employee who works 3 days in the week in which a holiday falls shall be paid for the holiday.

a. PAID HOLIDAYS: New Year's Day, President's Day, Memorial Day, July Fourth, Victory Day, Labor Day, Columbus Day, Veterans Day, Thanksgiving Day & Christmas Day.

Hazmat work: \$2.00 per hour additional.
Tunnel/Shaft work: \$5.00 per hour additional.

* ROOF0033-002 06/01/2021

	Rates	Fringes
ROOFER.....	\$ 39.40	29.06

SURI1999-002 04/12/1999

	Rates	Fringes
BRICKLAYER.....	\$ 20.45	11.40
CARPENTER		
Including Acoustical Ceiling Installation, Drywall Hanging, & Metal Stud Framing.....	\$ 15.32	9.65
Cement Mason/Finisher.....	\$ 20.45	11.40
Drywall Finisher/Taper.....	\$ 20.55	8.50
FLOOR LAYER: Carpet.....	\$ 15.62	9.65

INSULATOR - BATT.....	\$ 19.56	9.65
LABORER		
Unskilled, Landscape, & Brick Mason Tender.....	\$ 18.47	8.10
PAINTER (Brush and Roller).....	\$ 20.55	8.50
PLASTERER.....	\$ 13.50	2.45
PLUMBER.....	\$ 23.96	8.95
Power Equipment Operator		
Backhoe.....	\$ 20.27	8.98
SPRINKLER FITTER.....	\$ 24.24	9.81

WELDERS - Receive rate prescribed for craft performing operation to which welding is incidental.

=====
Note: Executive Order (EO) 13706, Establishing Paid Sick Leave for Federal Contractors applies to all contracts subject to the Davis-Bacon Act for which the contract is awarded (and any solicitation was issued) on or after January 1, 2017. If this contract is covered by the EO, the contractor must provide employees with 1 hour of paid sick leave for every 30 hours they work, up to 56 hours of paid sick leave each year. Employees must be permitted to use paid sick leave for their own illness, injury or other health-related needs, including preventive care; to assist a family member (or person who is like family to the employee) who is ill, injured, or has other health-related needs, including preventive care; or for reasons resulting from, or to assist a family member (or person who is like family to the employee) who is a victim of, domestic violence, sexual assault, or stalking. Additional information on contractor requirements and worker protections under the EO is available at www.dol.gov/whd/govcontracts.

Unlisted classifications needed for work not included within the scope of the classifications listed may be added after award only as provided in the labor standards contract clauses (29CFR 5.5 (a) (1) (ii)).

The body of each wage determination lists the classification and wage rates that have been found to be prevailing for the cited type(s) of construction in the area covered by the wage determination. The classifications are listed in alphabetical order of ""identifiers"" that indicate whether the particular rate is a union rate (current union negotiated rate for local), a survey rate (weighted average rate) or a union average rate (weighted union average rate).

Union Rate Identifiers

A four letter classification abbreviation identifier enclosed in dotted lines beginning with characters other than ""SU"" or ""UAVG"" denotes that the union classification and rate were prevailing for that classification in the survey. Example:

PLUM0198-005 07/01/2014. PLUM is an abbreviation identifier of the union which prevailed in the survey for this classification, which in this example would be Plumbers. 0198 indicates the local union number or district council number where applicable, i.e., Plumbers Local 0198. The next number, 005 in the example, is an internal number used in processing the wage determination. 07/01/2014 is the effective date of the most current negotiated rate, which in this example is July 1, 2014.

Union prevailing wage rates are updated to reflect all rate changes in the collective bargaining agreement (CBA) governing this classification and rate.

Survey Rate Identifiers

Classifications listed under the ""SU"" identifier indicate that no one rate prevailed for this classification in the survey and the published rate is derived by computing a weighted average rate based on all the rates reported in the survey for that classification. As this weighted average rate includes all rates reported in the survey, it may include both union and non-union rates. Example: SULA2012-007 5/13/2014. SU indicates the rates are survey rates based on a weighted average calculation of rates and are not majority rates. LA indicates the State of Louisiana. 2012 is the year of survey on which these classifications and rates are based. The next number, 007 in the example, is an internal number used in producing the wage determination. 5/13/2014 indicates the survey completion date for the classifications and rates under that identifier.

Survey wage rates are not updated and remain in effect until a new survey is conducted.

Union Average Rate Identifiers

Classification(s) listed under the UAVG identifier indicate that no single majority rate prevailed for those classifications; however, 100% of the data reported for the classifications was union data. EXAMPLE: UAVG-OH-0010 08/29/2014. UAVG indicates that the rate is a weighted union average rate. OH indicates the state. The next number, 0010 in the example, is an internal number used in producing the wage determination. 08/29/2014 indicates the survey completion date for the classifications and rates under that identifier.

A UAVG rate will be updated once a year, usually in January of each year, to reflect a weighted average of the current negotiated/CBA rate of the union locals from which the rate is based.

WAGE DETERMINATION APPEALS PROCESS

1.) Has there been an initial decision in the matter? This can be:

- * an existing published wage determination
- * a survey underlying a wage determination
- * a Wage and Hour Division letter setting forth a position on a wage determination matter
- * a conformance (additional classification and rate) ruling

On survey related matters, initial contact, including requests for summaries of surveys, should be with the Wage and Hour Regional Office for the area in which the survey was conducted because those Regional Offices have responsibility for the Davis-Bacon survey program. If the response from this initial contact is not satisfactory, then the process described in 2.) and 3.) should be followed.

With regard to any other matter not yet ripe for the formal process described here, initial contact should be with the Branch of Construction Wage Determinations. Write to:

Branch of Construction Wage Determinations
Wage and Hour Division
U.S. Department of Labor
200 Constitution Avenue, N.W.
Washington, DC 20210

2.) If the answer to the question in 1.) is yes, then an interested party (those affected by the action) can request review and reconsideration from the Wage and Hour Administrator (See 29 CFR Part 1.8 and 29 CFR Part 7). Write to:

Wage and Hour Administrator
U.S. Department of Labor
200 Constitution Avenue, N.W.
Washington, DC 20210

The request should be accompanied by a full statement of the interested party's position and by any information (wage payment data, project description, area practice material, etc.) that the requestor considers relevant to the issue.

3.) If the decision of the Administrator is not favorable, an interested party may appeal directly to the Administrative Review Board (formerly the Wage Appeals Board). Write to:

Administrative Review Board
U.S. Department of Labor
200 Constitution Avenue, N.W.
Washington, DC 20210

4.) All decisions by the Administrative Review Board are final.

=====

END OF GENERAL DECISION"

GENERAL CONDITIONS

*Pawtucket Housing Authority
St. germain Manor Deck Improvements
Pawtucket, Rhode Island*

General Conditions - 1

INDEX TO GENERAL CONDITIONS

PART I

1. CONTRACT AND CONTRACT DOCUMENTS
2. DEFINITIONS
3. QUANTITIES OF ESTIMATE
4. CONFLICTING CONDITIONS
5. PROVISIONS OF LAW DEEMED INSERTED
6. NOTICE AND SERVICE THEREOF
7. GRATUITIES
8. COVENANT AGAINST CONTINGENT FEES
9. REMEDIES

PART II

10. REPRESENTATIONS OF THE CONTRACTOR
11. CONTRACTOR'S OBLIGATIONS
12. TIME FOR COMPLETION AND LIQUIDATED DAMAGES
13. TERMINATION FOR DEFAULT, DAMAGES FOR DELAY, TIME EXTENSIONS
14. CONTRACT SECURITY
15. ADDITIONAL OR SUBSTITUTE BOND
16. INDEMNITY
17. SUPERINTENDENTS BY THE CONTRACTOR
18. CONTRACTOR TO LAY OUT HIS OWN WORK
19. COMPETENT HELP TO BE EMPLOYED
20. PERMITS AND REGULATIONS
21. CONSTRUCTION SCHEDULE AND PERIODIC ESTIMATES
22. SEQUENCE OF THE WORK
23. AUDIT; ACCESS TO RECORDS
24. REPORTS, RECORDS AND DATA
25. DIFFERING SITE CONDITIONS
26. PAYMENTS BY THE CONTRACTOR
27. GENERAL GUARANTEE
28. COMPLETENESS OF THE WORK
29. CARE OF THE WORK
30. PROTECTION OF CONSTRUCTION FEATURES
31. SAFETY AND HEALTH REGULATIONS
32. PROTECTION OF WORK AND PROPERTY EMERGENCY
33. FIRE PREVENTION AND PROTECTION
34. PROTECTION OF LIVES AND HEALTH
35. PROTECTION AGAINST HIGH WATER AND STORM
36. FIRST AID TO INJURED
37. HURRICANE PROTECTION
38. USE OF PREMISES AND REMOVAL OF DEBRIS
39. CORRECTION OF WORK
40. FAILURE TO REPAIR
41. WEATHER CONDITIONS
42. WORK IN COLD WEATHER
43. BUS LINE INTERFERENCE
44. NIGHTWORK
45. LIGHTS, BARRIERS, WATCHMEN AND INDEMNITY

*Pawtucket Housing Authority
St. germain Manor Deck Improvements
Pawtucket, Rhode Island*

- 46. LOADING
- 47. DISPOSAL OF MATERIALS
- 48. FINISHING AND CLEANING UP
- 49. SPIRITUOUS LIQUORS
- 50. DUST CONTROL

PART III

- 51. THE OWNER'S AUTHORITY
- 52. ALL WORK SUBJECT TO CONTROL BY THE OWNER
- 53. THE OWNER'S CONTROL NOT LIMITED
- 54. RIGHT OF THE OWNER TO TERMINATE THE CONTRACT
- 55. TERMINATION FOR CONVENIENCE
- 56. RIGHTS OF ACCESS
- 57. RIGHTS-OF-WAY AND SUSPENSION OF WORK
- 58. CONFORMANCE WITH DIRECTIONS
- 59. INTERPRETATION OF THE DRAWINGS AND SPECIFICATIONS
- 60. SUSPENSION OF WORK
- 61. INSPECTION

PART IV

- 62. SUBCONTRACTORS
- 63. MUTUAL RESPONSIBILITY OF CONTRACTORS
- 64. ASSIGNMENTS
- 65. SEPARATE CONTRACTS
- 66. WORK BY OTHERS

PART V

- 67. WAGE UNDERPAYMENTS AND ADJUSTMENTS
- 68. PAYMENT OF EMPLOYEES
- 69. NON-DISCRIMINATION IN EMPLOYMENT
- 70. APPRENTICES

PART VI

- 71. SHOP OR SETTING DRAWINGS
- 72. WORK TO BE ACCOMPLISHED IN ACCORDANCE WITH THE DRAWINGS AND SPECIFICATIONS
- 73. CONTRACTOR TO CHECK DIMENSIONS AND SCHEDULES
- 74. AREA CALCULATION
- 75. ADDITIONAL INSTRUCTIONS AND DETAIL DRAWINGS
- 76. MATERIALS, SERVICES AND FACILITIES
- 77. CONTRACTOR'S TITLE TO MATERIALS
- 78. INSPECTION AND TESTING OF MATERIALS
- 79. DEFECTIVE MATERIALS
- 80. PATENTS
- 81. "OR APPROVED EQUAL CLAUSE"

PART VII

- 82. INSURANCES

PART VIII

- 83. COMPENSATION TO BE PAID TO THE CONTRACTOR
- 84. PAYMENTS TO CONTRACTOR
- 85. CHANGE ORDERS
- 86. CHANGES IN THE WORK
- 87. CLAIMS FOR EXTRA COST
- 88. CHANGES AND MODIFICATIONS
- 89. ACCEPTANCE OF THE FINAL PAYMENT CONSTITUTES RELEASE

PART I

ARTICLE 1: CONTRACT AND CONTRACT DOCUMENTS

The drawings, specifications, and addenda enumerated in Article 1 of the Special Conditions, the Advertisement for Bids, the Information for Bidders, and the Bid Proposal as accepted by the OWNER, shall be binding upon the parties to this Agreement as if fully set forth therein. Whenever the terms "Contract Documents" are used, it shall mean and include this Contract, Special Conditions, General Conditions, Information for Bidders, the Bid Proposal, Addenda, the Technical Specifications and the Drawings. The OWNER shall interpret his own requirements. In case of conflict or inconsistency between the provisions of the signed portions of the Contract Documents and those of the specifications, the provisions of the signed portions shall govern.

ARTICLE 2: DEFINITIONS

The following terms are defined as follows. Note, the list is not all inclusive and interpretation of other terms will be made by the Owner's representative as needed:

- A. CHANGE ORDER - A written order to the Contractor authorizing an addition, deletion or revision in the work within the general scope of the Contract Documents, or authorizing an adjustment in the Contract Price or Contract Time.
- B. CONTRACT DOCUMENTS - The Contract, including Advertisement for Bids, Information for Bidders, Bid, Bid Bond, Agreement, Payment Bond, Performance Bond, General Conditions, Special Conditions, Technical Specifications, Notice of Award, Notice to Proceed, Change Order, Drawings, and Addenda.
- C. CONTRACTOR - A person, firm or corporation with whom the Contract is made by the OWNER.
- D. DRAWINGS - The part of the Contract Documents which show the characteristics and scope of the work to be performed and which have been prepared by the Engineer.
- E. ENGINEER - Shall mean for the purpose of this Contract the firm of Resource Control Associates, Inc. who shall act as the authorized representative of the OWNER whenever the authorized representative of the OWNER whenever reference is made for such authorization.
- F. FIELD ORDER - A written order effecting a change in the work not involving an adjustment in the Contract Price or an extension of the Contract Time, issued by the Engineer to the Contractor during construction.
- G. NOTICE OF AWARD - The written notice of the acceptance of the Bid from the OWNER to the successful Bidder.
- H. NOTICE TO PROCEED - Written communication issued by the OWNER to the Contractor authorizing him to proceed with the work and establishing the date of commencement of the work.
- I. OWNER - Shall mean, for the purpose of this Contract, **Pawtucket Housing Authority** as elsewhere defined in the Agreement section of the Contract Documents.
- J. RESIDENT PROJECT REPRESENTATIVE - The authorized representative of the OWNER who is assigned to the Project Site or any part thereof.
- K. SHOP DRAWINGS - All drawings, diagrams, illustrations, brochures, schedules and other data which are prepared by the Contractor, a Subcontractor, Manufacturer, Supplier or Distributor, which illustrates how specific portions of the work shall be fabricated or installed.
- L. SPECIFICATIONS (TECHNICAL SPECIFICATIONS) - A part of the Contract Documents consisting of written descriptions of a technical nature of materials, equipment, construction systems, standards and workmanship.

- M. SUBCONTRACTOR - A person, firm, or corporation supplying labor and materials, or only labor, for work at the site of the project; for, and under a separate Contract or Agreement with the Contractor.
- N. SUBSTANTIAL COMPLETION - That date as certified by the Engineer when the construction of the Project or the specified part thereof is sufficiently completed, in accordance with the Contract Documents, so that the Project or specified part can be utilized for the purpose for which it is intended.
- O. WORK ON THE PROJECT - Work to be performed at the location of the project, including the transportation of materials and supplies to or from the site by employees of the Contractor or any Subcontractor.

ARTICLE 3: QUANTITIES OF ESTIMATE

Whenever the estimated quantities of work to be done and materials to be furnished under this Contract are shown in any of the documents including the Bid Proposal, they are given for use in comparing bids and the right is especially reserved by the OWNER to increase or diminish them as may be deemed necessary or desirable by the OWNER. Such increases or decreases shall in no way affect this Contract, nor shall any such increases or decreases give cause for claims or liabilities for damages.

ARTICLE 4: CONFLICTING CONDITIONS

Any provisions of these General Conditions which may be in conflict or inconsistent with any of the articles in the Special Conditions shall be void to the extent of such conflict or inconsistency.

ARTICLE 5: PROVISIONS OF LAW DEEMED INSERTED

Each and every provision of law and clause required by law to be inserted in this Contract shall be deemed to be inserted herein and the Contract shall be read and enforced as though it were included herein, and if through mistake or otherwise, any such provision is not inserted, or is not correctly inserted, the Contract shall forthwith be physically amended to make such insertion or correction.

ARTICLE 6: NOTICE AND SERVICE THEREOF

The service of any notice, letter, or other communication shall be deemed to have been made by one of the contracting parties on the other party to the Contract when such letter, notice or other communication has been delivered to the legal office address of the addressee, by a duly authorized representative of the address or in person, or when such notice, letter, or other communication has been deposited in any regularly maintained mailbox of the United States Post Office, in a properly addressed, postpaid wrapper. The date of such service shall be considered to be the date of such personal delivery or mailing.

The address of the Contractor noted in his bid and/or the address of his field office on or near the site of work shall be considered his legal address for the purposes as set forth above.

ARTICLE 7: GRATUITIES

- A. If it is found, after notice and hearing, by the OWNER that gratuities (in the form of entertainment, gifts or otherwise) were offered or given by the Contractor, or any agent or representative of the Contractor, to any official, employee or agent of the Owner, or of the State, with a view toward securing a contract or securing favorable treatment with respect to the awarding or amending, or the making of any determinations with respect to the performance of this Contract, the Owner, may by written notice to the Contractor, terminate the right of the Contractor to proceed under

*Pawtucket Housing Authority
St. germain Manor Deck Improvements
Pawtucket, Rhode Island*

this Contract or may pursue each other's rights and remedies provided by law or under this Contract: Provided, that the existence of the facts upon which the Owner makes such findings shall be in issue and may be reviewed in proceedings pursuant to the "Remedies" clause of this Contract.

- B. In the event this Contract is terminated as provided in Paragraph (a) hereof, the Owner shall be entitled (l) to pursue the same remedies against the Contractor as it could pursue in the event of a breach of the Contract by the Contractor, and (a) as a penalty in addition to any other damages to which it may be entitled by law, to exemplary damages in an amount (as determined by the Owner) which shall be not less than three nor more than ten times the cost incurred by the Contractor in providing any such gratuities to any such officer or employee.

ARTICLE 8: COVENANT AGAINST CONTINGENT FEES

The Contractor warrants that no person or selling agency has been employed or retained to solicit or secure this Contract upon an agreement or understanding for a commission, percentage, brokerage, or contingent fee, excepting bona fide employees or bona fide established commercial or selling agencies maintained by the Contractor for the purpose of securing business. For breach or violation of this warranty, the Owner shall have the right to annul this Contract without liability or in its discretion to deduct from the Contract Price or consideration, or otherwise recover, the full amount of such commission, percentage, brokerage, or contingent fee.

ARTICLE 9: REMEDIES

Except as may be otherwise provided in this Contract, all claims, counterclaims, disputes and other matters in question between the OWNER and the Contractor arising out of or relating to this agreement or the breach thereof will be decided in a court of competent jurisdiction within the State in which the Owner is located.

PART II

The rights and obligations of the Contractor under this Contract shall include, but not be limited to the following:

ARTICLE 10: REPRESENTATIONS OF THE CONTRACTOR

The Contractor represents and warrants:

- A. That he is financially solvent and that he is experienced and competent to perform the type of work required under this Contract and that he is able to furnish the plant materials, supplies, or equipment that may be necessary to perform the work as specified.
- B. That he is familiar with all Federal, State and municipal laws, ordinances, orders, and regulations which may in any way affect the project work, or the employment of persons thereon, including but not limited to any special acts relating to the work or to the project of which he is a part.
- C. That such temporary and permanent work required by the Contract Documents to be done by him will be satisfactorily constructed and can be used for the purpose for which it was intended and that such construction will not injure any person or damage property.
- D. That he has carefully examined the drawings, specifications, and addenda, if any, and the site of the work and that from his own investigations, he has satisfied himself as to the nature and location of the work, the character of equipment and other facilities needed for the performance of the work, the general and local conditions, and all other items that may affect the work.
- E. That he is aware of the hazards involved in the work and the danger to life and property both evident and inherent and that he will conduct the work in a careful and safe manner without

*Pawtucket Housing Authority
St. germain Manor Deck Improvements
Pawtucket, Rhode Island*

- injury to persons or property.
- F. That he prepared and submitted his bid for the project with no collusion with other contractors or bidders.

ARTICLE 11: CONTRACTOR'S OBLIGATIONS

The Contractor shall perform all work in a good workmanlike manner, and in accordance with the plans and specifications and any supplements thereto, and according to any directions or orders given by the OWNER. He shall furnish all supplies, materials, facilities, equipment, and means necessary or proper to perform and complete the work required by this Contract. He shall furnish, erect, maintain, and remove any construction plant or temporary work as may be required. He alone shall be responsible for the safety, efficiency, and adequacy of his plant, appliances, and methods, and for any damage which may result from their failure or their improper construction, maintenance, or operation. The Contractor shall observe, comply with, and be subject to all terms, conditions, requirements, and limitations of the Contract and Specifications and shall do, carry on, and complete the entire work to the satisfaction of the OWNER.

The Contractor shall be solely responsible for all the work and shall provide all precautionary measures necessary for preventing injury to persons or damage to property. All injury or damage of whatever nature resulting from the work or resulting to persons, property, or the work during its progress, from whatever cause, shall be the responsibility of the Contractor.

The Contractor shall hold the OWNER and Engineer, or their duly authorized agents, harmless and defend and indemnify them against damages or claims for damages due to injuries to persons or property arising out of the execution of the project work, and for damages to materials furnished for the work, for infringement of inventions, patents, and patent rights used in doing the work, and for any act, omission, or instance of neglect by the Contractor, his agents, employees, or subcontractors.

The Contractor shall bear all losses resulting to him, including but not limited to losses sustained on account of the character, quality, or quantity of any part of the work, or all parts of the work, or because the nature of the conditions in or on the project site are different from what was estimated or indicated, or on account of the weather, elements, or other causes.

ARTICLE 12: TIME FOR COMPLETION AND LIQUIDATED DAMAGES

- A. It is hereby understood and mutually agreed by and between the Contractor and the OWNER that the date of beginning and the time of completion of the work are as specified in this Contract; and it is further mutually understood and agreed that the work embraced in this Contract shall be commenced on a date to be specified in the Notice to Proceed.
- B. The Contractor agrees that said work shall be prosecuted regularly, diligently, and uninterruptedly at such rate of progress as will insure full completion thereof within the time specified, and further, that time of completion as agreed upon is reasonable, taking into consideration the average climatic range and usual industrial conditions prevailing in this locality.
- C. If the said Contractor shall neglect, fail or refuse to complete the work within the time herein specified, or any proper extension thereof granted by the OWNER, then the Contractor does hereby agree, as a partial consideration for the awarding of this Contract, to pay to the OWNER the amount of three hundred dollars (\$300.00), not as a penalty, but as liquidated damages for such Breach of Contract as hereinafter set forth for each and every calendar day that the Contractor shall be in default after the time stipulated in the Contract for completing the work.
- D. The said amount is fixed and agreed upon by and between the OWNER and the Contractor, and said amount is agreed to be the amount of damages the OWNER would sustain in such an event as the above-mentioned, and said amount shall be retained from time to time by the OWNER from current periodical payments.
- E. It is further agreed that time is of the essence in each and every portion of the Contract and

Specifications; where in a definite and certain length of time is fixed for the performance of any act whatsoever; and where under the Contract an additional time is allowed for the completion of any work, the new time limit fixed by such extension shall be by the Contractor and shall not be charged when the delay in completion of the work is due to:

1. Any preference, priority, or allocation order duly issued by the government, subsequent to the date of the Contract.
 2. Unforeseeable causes beyond the control and without the fault or negligence of the Contractor, including, but not restricted to acts of God, or of the public enemy, act of the OWNER, acts of another contractor, fires, floods, epidemics, strikes, and unusually severe weather.
 3. Any delays of subcontractors or suppliers approved by the OWNER.
- F. Provided further that the Contractor shall within ten days (10) from the beginning of the delay, unless the OWNER shall grant a further period of time prior to the date of final settlement of the Contract, notify the OWNER in writing of the causes of the delay. The OWNER shall ascertain the facts and extent of the delay and notify the Contractor within a reasonable time of its decision in the matter. In the event of a favorable decision, the Contractor will be entitled only to a modification in the contract time and will not be entitled to a modification in contract price.

ARTICLE 13: TERMINATION FOR DEFAULT; DAMAGES FOR DELAY; TIME EXTENSIONS

- A. If the Contractor refuses or fails to prosecute the work, or any separable part thereof, with such diligence as will insure its completion within the time specified in this Contract, or any extension thereof, or fails to complete said work within such time, the OWNER may, by written notice to the Contractor, terminate his right to proceed with the work or such part of the work as to which there has been a delay. In such event, the OWNER may take over the work and prosecute the same to completion, by Contract other otherwise, and may take possession of and utilize in completing the work such materials, appliances, and plant as may be on the site of the work and necessary therefore. Whether or not the Contractor's right to proceed with the work is terminated, he and his sureties shall be liable for any damage to the OWNER resulting from his refusal or failure to complete the work within the specified time.
- B. If fixed and agreed liquidated damages are provided in the Contract and if the OWNER so terminates the Contractor's right to proceed, the resulting damage will consist of such liquidated damages until such reasonable time as may be required for final completion of the work together with any increased costs occasioned the OWNER in completing the work.
- C. If fixed and agreed liquidated damages are provided in the Contract and if the OWNER does not so terminate the Contractor's right to proceed, the resulting damage will consist of such liquidated damages until the work is completed or accepted.
- D. The Contractor's right to proceed shall not be so terminated nor the Contractor charged with resulting damage if:
 1. The delay in the completion of the work arises from causes other than normal weather beyond the control and without the fault or negligence of the Contractor, including but not restricted to, acts of God, acts of the public enemy, acts of the OWNER in either its sovereign or contractual capacity acts of another contractor in the performance of a Contract with the OWNER, fires, floods, epidemics, quarantine restrictions, strikes, freight embargoes, unusually severe weather, or delays of subcontractors or suppliers arising from causes other than normal weather beyond the control and without the fault or negligence of both the Contractor and such subcontractors or suppliers; and
 2. The Contractor, within 10 days from the beginning of any such delay (unless the OWNER grants a further period of time before the date of final payment under the Contract), notifies the OWNER in writing of the causes of delay. The OWNER shall ascertain the

facts and the extent of the delay and extend the time for completing the work when, in his judgment, the findings of fact justify such an extension and his findings of fact shall be final and conclusive on the parties, subject only to appeal as provided in the Remedies clause of this Contract. In the event of a favorable decision, the Contractor will be entitled only to a modification in the contract time and will not be entitled to a modification in contract price.

- E. If, after notice of termination of the Contractor's right to proceed under the provisions of this clause, it is determined for any reason that the Contractor was not in default under the provisions of this clause, or that the delay was excusable under the provisions of this clause, the rights and obligations of the parties shall, if the Contract contains a clause providing for termination for convenience of the OWNER, be the same as if the notice of termination has been issued pursuant to such clause. If, in the foregoing circumstances, this Contract does not contain a clause providing for termination for convenience of the OWNER, the Contract shall be equitably adjusted accordingly; failure to agree to any such adjustment shall be subject to the Remedies clause of this Contract.
- F. The rights and remedies of the OWNER provided in this clause are in addition to any other rights and remedies provided by law or under this Contract.
- G. As used in paragraph (d) (1) of this clause, the term, "Subcontractors or suppliers", means subcontractors or suppliers at any tier.

ARTICLE 14: CONTRACT SECURITY

The Contractor shall furnish a surety bond in an amount equal to at least one hundred percent (100%) of the Contract Price as security for the faithful performance of the Contract, and for the payment of all persons performing labor on the project under this Contract and furnishing materials, equipment and all other incidentals in connection with this Contract. This Surety on such a bond shall be a duly authorized surety company satisfactory to the OWNER and the cost of the same shall be paid by the Contractor. Prior to the starting of any work, the bonds must be approved by the OWNER.

ARTICLE 15: ADDITIONAL OR SUBSTITUTE BOND

If at any time the OWNER, for justifiable cause, shall become dissatisfied with any Surety or Sureties holding payment bonds, the Contractor shall, within five (5) days after notice from the OWNER to do so, substitute an acceptable bond or bonds in such form and signed by such other Surety as may be satisfactory to the OWNER. The premiums of such bonds shall be paid by the Contractor. No further payments will be deemed due, nor will be made until the new Surety or Sureties shall have furnished such an acceptable bond to the OWNER.

ARTICLE 16: INDEMNITY

The Contractor shall at all times indemnify and save harmless the OWNER and the Engineer, their servants and agents, from any and all claims and from any suits, litigation, damages, losses or the like arising out of injuries sustained or alleged to have been sustained by any persons or property in connection with the contract work, caused in whole or in part by acts or omissions of the Contractor, his subcontractors, material men, or anyone directly or indirectly connected with the contract work.

ARTICLE 17: SUPERINTENDENTS BY THE CONTRACTOR

The Contractor shall give the work the constant attention necessary to facilitate the progress thereof and shall cooperate with the OWNER in every possible way.

At the site of the work, the Contractor shall, at all times, employ a construction superintendent who shall have full authority to act for the Contractor. It is understood that the employment of such representative shall be acceptable to the OWNER and shall be such a person as can be continued in the capacity for the duration of the Contract, unless he ceases to be on the Contractor's payroll.

ARTICLE 18: CONTRACTOR TO LAY OUT HIS OWN WORK

The OWNER will establish such general reference points as in his judgment will enable the Contractor to proceed with the work. The Contractor, at his own expense, shall provide all materials and equipment and such qualified helpers as the OWNER may require for setting the general reference points and shall protect and preserve all stakes, benches, and other markers used to identify the reference points. The Contractor shall lay out all the Contract work from the above and shall be responsible for the accuracy of all lines, grades and measurements.

ARTICLE 19: COMPETENT HELP TO BE EMPLOYED

The Contractor shall employ experienced foremen, craftsmen and other workmen competent in the work in which they are to be engaged.

ARTICLE 20: PERMITS AND REGULATIONS

The Contractor shall procure and pay for all permits, licenses, and approvals necessary for the execution of the Contract work.

The Contractor shall comply with all laws, regulations, ordinances, orders and rules relating to the performance of the work, the protection of the adjacent property, and the maintenance of passageways, guard fences, and other protective facilities.

ARTICLE 21: CONSTRUCTION SCHEDULE AND PERIODIC ESTIMATES

- A. Within five (5) days after the date of "Notice to Proceed", the Contractor shall deliver to the OWNER an estimated construction progress schedule in a form satisfactory to the OWNER, showing the proposed dates of commencement and completion of each of the various subdivisions of work required under the Contract Documents and the anticipated amount of each monthly payment that will become due the Contractor in accordance with the progress schedule.
- B. The Contractor shall also furnish on forms to be supplied by the OWNER:
 1. A detailed estimate, giving a complete breakdown of the contract price; and
 2. Periodic itemized estimates of the work done for the purpose of making partial payments thereon.
- C. The Contractor shall perform the work of this Contract to conform with the schedule as approved by the OWNER, except that the OWNER reserves the right to amend and alter the construction schedule at any time, in a manner which is deemed to be in the best interest of the OWNER to do so. The Contractor shall arrange his work to conform to this schedule as it may be revised from time to time by the OWNER, at no additional expense to the OWNER.
- D. The Contractor shall notify the OWNER immediately of any circumstances, which may affect the performance of the work in accordance with the current construction schedule.

ARTICLE 22: SEQUENCE OF THE WORK

The Contractor shall be required to prosecute his work in accordance with a schedule prepared by him in advance in accordance with additional requirements specified herein and approved by the OWNER. This scheduling shall state the methods and shall forecast the times of doing each portion of the work. Before beginning any portion of the work, the Contractor shall give the OWNER advance notice and ample time for making necessary preparations.

ARTICLE 23: AUDIT; ACCESS TO RECORDS

The Contractor shall maintain books, records, documents and other evidence directly pertinent to performance of work under this Contract in accordance with generally accepted accounting principles and practices. The Contractor shall also maintain the financial information and data used by the Contractor in the preparation or support of the cost submission or for any negotiated contract or change order and a copy of the cost summary submitted to the OWNER. The Contractor will provide proper facilities for such access and inspection.

Audits conducted pursuant to this Provision shall be in accordance with generally accepted auditing standards and established procedures and guidelines of the reviewing or audit agency (ies).

The Contractor agrees to the disclosure of all information and reports resulting from the access to records pursuant to paragraphs above, to any of the agencies referred to above, provided that the Contractor is afforded the opportunity for an audit exist conference, and an opportunity to comment and submit any supporting documentation on the pertinent portions of the draft audit report that the final audit report will include written comments of reasonable length, if any, of the Contractor.

Records under paragraphs above shall be maintained and made available during performance on work under this Contract and until three years from the date of final payment for the project. In addition, those records which related to any "Dispute", appeal agreement, or litigation, or the settlement of claims arising out of such performance, or costs or items to which an audit exception has been taken, shall be maintained and made available until three years after the date of resolution of such appeal, litigation, claim or exception.

ARTICLE 24: REPORTS, RECORDS AND DATA

The Contractor and each of his subcontractors, shall submit to the OWNER such schedules of quantities, and costs, progress schedules, payrolls, reports, estimates, records and other data as the OWNER may request concerning the work performed or to be performed under this Contract.

ARTICLE 25: DIFFERING SITE CONDITIONS

- A. The Contractor shall promptly and before such conditions are disturbed, notify the OWNER in writing of: (1) subsurface or latent physical conditions at the site differing materially from those indicated in this Contract, or (2) unknown physical conditions at the site, of any unusual nature, differing materially from those ordinarily encountered and generally recognized as inhering in work of the character provided for in this Contract. The OWNER shall promptly investigate the conditions and if he finds that such conditions do materially so differ and cause an increase or decrease in the Contractor's cost of, or the time required for, performance of any of the work under this Contract, whether or not changed as a result of such conditions, an equitable adjustment shall be made and the Contract modified in writing accordingly.
- B. No claim of the Contractor under this clause shall be allowed unless the Contractor has given the notice required in (a) above; provided, however, the time prescribed therefore may be extended by the OWNER.

*Pawtucket Housing Authority
St. germain Manor Deck Improvements
Pawtucket, Rhode Island*

- C. No claim by the Contractor for an equitable adjustment hereunder shall be allowed if asserted after final payment under this Contract.

ARTICLE 26: PAYMENTS BY THE CONTRACTOR

The Contractor shall pay:

- A. For all transportation and utility services not later than the 20th day of each calendar month following that in which services were rendered.
- B. For all materials, tools, and other expendable equipment to the extent of 90 percent of the cost thereof, not later than the 20th day of the calendar month following that in which such items were delivered to the site of work, and the balance of the cost thereof not later than the 30th day following the completion of that part of the work in or on which such material tools, or equipment are incorporated or used.
- C. To each of his subcontractors, not later than the 5th day following each payment to the Contractor, the respective amounts allowed the Contractor on account of the work performed by his subcontractors to the extent of such subcontractor's interest therein.
- D. Payment for trucking or materials furnished - Withholding of sums due. A contractor or subcontractor on public works authorized by a proper authority shall pay any obligation or charge for trucking and material which have been furnished for the use of such contractor or subcontractor, in connection with the public works being performed by him, within ninety (90) days after such obligation or charge is incurred or the trucking service has been performed or the material has been delivered to the site of the work, whichever is later. When it is brought to the notice of the proper authority in a city or town, or the proper authority in the state having supervision of such contract, that such obligation or charge has not been paid by the contractor or subcontractor, the proper authority may deduct and hold for a period not exceeding sixty (60) days, from sums of money due to the contractor or subcontractor, the equivalent amount of such sums certified by a trucker or material man creditor as due him, as provided in this section, and which the proper authority determines is reasonable for trucking performed or materials furnished for such public works.
- E. Ascertainment of prevailing rate of wages and other payments - Specification of rate in call for bids and in contract. Before awarding any contract for public works to be done, the proper authority shall ascertain from the director of labor the general prevailing rate of the regular, holiday and overtime wages paid and the general prevailing payments on behalf of employees only, to lawful welfare, pension, vacation, apprentice training and educational funds (payments to said funds must constitute an ordinary business expense deduction for federal income tax purposes by contractors) in the city, town, village or other appropriate political subdivision of the state in which the work is to be performed, for each craft, mechanic, teamster, laborer or type of workman needed to execute the contract for the public works, and shall specify in the call for bids for the contract and in the contract itself the general prevailing rate of the regular, holiday, and overtime wages paid and the payments on behalf of employees only, to such welfare, pension vacation, apprentice training and education funds existing in the locality for each craft, mechanic, teamster, laborer or type of workman needed to execute the contract or work.
1. Every call for bids for every contract in excess of one thousand dollars (\$1,000), to which the state of Rhode Island or any political subdivision thereof is party, for construction, buildings or public works of the state of Rhode Island or any political subdivision thereof, and which requires or involves the employment of employees shall contain a provision stating the minimum wages to wages that will be determined by the director of labor to be prevailing character similar to the contract work in the city, town, village, or which the work is to be performed; and every contract shall contain a stipulation that the

*Pawtucket Housing Authority
St. germain Manor Deck Improvements
Pawtucket, Rhode Island*

contractor or his subcontractor shall pay all unconditionally and not less often than once a week, and without subsequent deduction or rebate on any account, the full amounts those stated in the call for bids, regardless of any contractual relationships which may be alleged to exist between the contract or subcontractor and such employees and that the scale of wages to be paid shall be posted by the contractor in a prominent and easily that there may be withheld from the contractors so much of accrued payments as may be considered necessary to pay to such employees employed by the contractor or any subcontractor on the work difference between the rates of wages required by the contract to be paid said employees on the work and the rates or wages received by such employees on the work and the rates of wages received by such employees and not refunded to the contractor, subcontractors, or their agents.

2. The terms "wages", "scale of wages", "wage rates", "minimum wages", and "prevailing wages" shall include:
 - a. the basic hourly rate of pay; and
 - b. the amount of:
 1. the rate of contribution made by a contractor or subcontractor to a trustee or to a third person pursuant to a fund, plan, or program; and
 2. The rate of costs to the contractor or subcontractor which may be reasonably anticipated in providing benefits to employees pursuant to an enforceable commitment to carry out a financially responsible plan or program which was communicated in writing to the employees affected, for medical or hospital care, pensions or retirement or death, compensation for injuries or illness resulting from occupational activity, or insurance to provide any of the foregoing, for unemployment benefits, life insurance, disability and sickness insurance, or accident insurance, for vacation and holiday pay, for defraying costs of apprenticeship or other similar programs, or for other bona fide fringe benefits but only where the contractor or subcontractor is not required by other federal, state, or local law to provide any of such benefits: Provided, that the obligation of a contractor or subcontractor to make payment in accordance with the prevailing wage determinations of the director of labor insofar as this chapter of this title and other acts incorporating this chapter of this title by reference are concerned may be discharged by the making of payments in cash, by the making of contributions of a type referred to in paragraph (b)(1), or by the assumption of an enforceable commitment to bear the costs of a plan or program of a type referred to in paragraph (b)(2), or any combination thereof, where the aggregate of any such payments, contributions, and costs is not less than the rate of pay described in paragraph (a) plus the amount referred to in paragraph (b).
3. The term "employees", as used in this section, shall include employees of contractors or subcontractors performing jobs on various types of public works including mechanics, apprentices, teamsters, chauffeurs and laborers engaged in the transportation of gravel or fill to the site of public works or removal of gravel or fill from one location to another on the site of public works, and the employment of such employees shall be subject to provisions of 1. and 2. of this section.

F. Specification in contract of amount and frequency of payment of wages.

ARTICLE 27: GENERAL GUARANTEE

Neither the final certificate of payment nor any provision in the Contract Documents nor partial or
Pawtucket Housing Authority
St. germain Manor Deck Improvements
Pawtucket, Rhode Island

entire occupancy of the premises by the OWNER shall constitute an acceptance of work not done in accordance with the Contract Documents or relieve the Contractor of liability in respect to any express warranties or responsibility for faulty workmanship or materials. The Contractor shall remedy any defects in the work and pay for any damage to other work resulting therefrom, which shall appear within a period of one year (1) from the date of final acceptance of the work, however the OWNER is not waiving any rights for defects beyond the 1 year warranty period. The OWNER will give final notice of observed defects with reasonable promptness.

ARTICLE 28: COMPLETENESS OF THE WORK

In addition to the specified or described portions of the work, all other work and all other materials, equipment and labor of whatever description, necessary or required to complete the work, or for carrying out the full intent of the drawings and specifications, such work, labor, materials, and equipment shall be provided by the Contractor, and payment therefore shall be considered as having been included in the prices stipulated for the appropriate item of work listed in the bid.

ARTICLE 29: CARE OF THE WORK

The Contractor shall take adequate precautions to protect existing sidewalks, curbs, pavements, utilities, adjoining property and such incidentals, and to avoid damage thereto. The Contractor shall completely repair any damage at no additional expense to the OWNER.

ARTICLE 30: PROTECTION OF CONSTRUCTION FEATURES

The Contractor shall be responsible for all damages to persons or property that occur as a result of his fault or negligence in connection with the prosecution of the work and shall be responsible for the proper care and protection of all materials delivered and work performed until completion and final acceptance by the OWNER, whether or not the same has been covered by partial payments made by the OWNER.

ARTICLE 31: SAFETY AND HEALTH REGULATIONS

- A. These Contract Documents, and the joint and several phases of construction hereby contemplated, are to be governed, at all times, by the applicable provisions of the Federal law(s) including but not limited to the following:
 - 1. Williams-Steiger Occupational Safety and Health Act, 1970, Public Law 92-596;
 - 2. Part 1910 of the Occupational Safety and Health Standards, Chapter XVII of Title 29, Code of Federal Regulations;
 - 3. This project is subject to all of the Safety and Health Regulations (CFR 29, Part 1926 and all subsequent amendments) as promulgated by the U.S. Department of Labor on June 24, 1974. Contractors are urged to become familiar with the requirements of these regulations.
- B. In the event of any inconsistencies between the above laws and regulations and the provisions of these Contract Documents, the laws and regulations shall prevail.

ARTICLE 32: PROTECTION OF WORK AND PROPERTY - EMERGENCY

- A. The Contractor shall at all times safely guard the OWNER'S property from injury or loss in connection with this Contract. He shall at all times safely guard and protect his own work, materials incorporated into the work or stockpiled at the site, and that of adjacent property, from

*Pawtucket Housing Authority
St. germain Manor Deck Improvements
Pawtucket, Rhode Island*

- damage. The Contractor shall replace or make good any such damage, loss or injury.
- B. In case of an emergency, which threatens loss or injury of property, and/or safety of life, the Contractor will be allowed to act, without previous instructions from the OWNER, in a diligent manner. He shall notify the OWNER immediately thereafter. Any claim for compensation by the Contractor due to such extra work shall be promptly submitted to the OWNER for approval.
 - C. Where the Contractor has not taken action but has notified the OWNER of an emergency threatening injury to persons or damage to the work or to any adjoining property, he shall act as instructed or authorized by the OWNER.
 - D. The amount of reimbursement claimed by the Contractor on account of any emergency action shall be determined in the manner provided elsewhere in the Contract Documents.

ARTICLE 33: FIRE PREVENTION AND PROTECTION

All State and municipal rules and regulations with respect to fire prevention, fire-resistant construction, and fire protection shall be strictly adhered to and all work and facilities necessary therefor shall be provided and maintained by the Contractor in an approved manner.

All fire protection equipment such as water tanks, hoses, pumps, extinguishers and other materials, and apparatus, shall be provided for the protection of the Contract work, temporary work, and adjacent property. Trained personnel experienced in the operation of all fire protection equipment and apparatus shall be available on the site whenever work is in progress, and at such other times as may be necessary for the safety of the public and the work.

ARTICLE 34: PROTECTION OF LIVES AND HEALTH

- A. In order to protect the lives and health of his employees under this Contract, the Contractor shall meet all pertinent provisions of the "Manual of Accident Prevention in Construction," issued by the Associated General Contractors of America, Inc., and shall maintain an accurate record of all cases of death, occupational diseases, and injuries requiring medical attention or causing loss of time of employment on the Contract work.
- B. The Contractor alone shall be responsible for the safety, efficiency, and adequacy of his plant, appliances, and methods, and for any damage which may result from their failure or their improper construction, maintenance or operation.

ARTICLE 35: PROTECTION AGAINST HIGH WATER AND STORM

The Contractor shall take all precautions to prevent damage to work or equipment by high water or by storms. The OWNER may prohibit the carrying out of work at any time when in his judgment high waters or storm conditions are unfavorable or unsuitable, or at any time regardless of the weather when proper precautions are not being taken to safeguard previously constructed work or work in progress.

In case of damage caused by the failure of the Contractor to take adequate precautions, the Contractor shall repair or replace equipment damaged and shall make such repairs or rebuild such parts of the damaged work as the OWNER may require, at no additional cost to the OWNER.

ARTICLE 36: FIRST AID TO INJURED

The Contractor shall keep in his office, ready for immediate use, all articles necessary for giving first aid to injured employees. He shall also provide arrangements for the immediate removal and hospital treatment of any employees injured on the work who require the same.

ARTICLE 37: HURRICANE PROTECTION

Should hurricane warnings be issued, the Contractor shall take every precaution to minimize danger to person, to the work and to adjacent property. These precautions shall include closing all openings, removing all loose materials, tools and equipment from exposed locations, and removing all scaffolding and other temporary work.

ARTICLE 38: USE OF PREMISES AND REMOVAL OF DEBRIS

The Contractor undertakes, at his own expense:

- A. To take every precaution against injuries to persons or damage to property.
- B. To store his apparatus, materials, equipment, and supplies in such orderly fashion at the site of the work as will not unduly interfere with the progress of his work or any others.
- C. To place upon the work or any part thereof, only such loads as are consistent with the safety of that portion of the work.
- D. To clean frequently all refuse, scrap, and debris caused by his operations, so that the work site is maintained in a neat, workmanlike appearance.
- E. To effect all cutting, fitting, or patching of his work required to make the same conform to the drawings and specifications, and except with the consent of the OWNER, not to cut or otherwise alter the work of any other contractor.
- F. Before final payment, to remove all surplus materials false work, temporary structures, including foundations thereof, plants of any description, and debris of any nature resulting from his operations, so that the site is left in a neat, orderly, and workmanlike condition.

ARTICLE 39: CORRECTION OF WORK

All work, materials, all processes of manufacture, and all methods of construction shall be at all times and places subject to the inspection of the OWNER, who shall be the final judge of the quality and suitability of the work performed under this Contract. Should any of the work performed fail to meet with his approval, it shall be forthwith reconstructed, made good, replaced, and/or corrected as the case may be, by the Contractor, at his own expense. Rejected material shall be immediately removed from the site.

If, in the opinion of the OWNER, it is undesirable to replace, reconstruct, or correct any of the work not performed in accordance with the Contract Documents, the compensation to be paid to the Contractor shall be reduced by such amounts as in the judgment of the OWNER shall be equitable.

ARTICLE 40: FAILURE TO REPAIR

Any emergency arising from the interruption of electric, gas, water, or sewer service due to the activities of the Contractor, shall be repaired by the Contractor as quickly as is possible.

If and when, in the opinion of the OWNER, the Contractor is not initiating repair work as expeditiously as possible upon notification to do so, the OWNER, may, at his own option, make the necessary repairs using his own forces or those of others. The cost of such repairs shall be subtracted from the payments due to the Contractor.

ARTICLE 41: WEATHER CONDITIONS

*Pawtucket Housing Authority
St. germain Manor Deck Improvements
Pawtucket, Rhode Island*

In the event of temporary suspension of the work, or during inclement weather, or whenever the OWNER shall direct, the Contractor shall, and shall cause his subcontractors to protect carefully his and their work and materials against damage or injury from the weather. If, in the opinion of the OWNER, any work or materials are damaged or injured by reason of failure to protect them or the part of the Contractor, or any of his subcontractors, or otherwise damaged or injured by the Contractor's negligence, or are found to be defective, such materials or work shall be removed and replaced at the expense of the Contractor.

ARTICLE 42: WORK IN COLD WEATHER

The OWNER may determine when conditions are unfavorable for work and may order the work or any portion thereof, suspended whenever, in his opinion, the conditions are not such as will insure first class work.

ARTICLE 43: BUS LINE INTERFERENCE

Whenever it may be necessary to interfere with any bus lines, notice shall be given to the corporation owning the same, and reasonable time will be given to said corporation to arrange the schedule for operation of the bus line, as it may be necessary.

ARTICLE 44: NIGHTWORK

Nightwork, or work on Saturdays, Sundays, or legal holidays requiring the presence of an engineer or inspector, will not be permitted except in case of emergency, and only upon the approval of the OWNER.

Should it be necessary for the OWNER to operate an organization for continuous nightwork or for emergency nightwork, the lighting, safety and other facilities, which are deemed necessary, shall be provided by the Contractor. Compensation for this work shall be considered as having been included in the prices stipulated for the appropriate items of work as listed in the bid, and no extra compensation will be paid by the OWNER.

ARTICLE 45: LIGHTS, BARRIERS, WATCHMEN AND INDEMNITY

The Contractor shall erect and maintain such barriers, lighting, warning lights, danger warning signals, and signs that will prevent accidents during the construction work and protect the work and insure the safety of personnel and the public at all times and places; the Contractor shall indemnify and protect the OWNER and Engineer in every respect from injury or damage whatsoever caused by any act of neglect by the Contractor or his subcontractors, or their servants or agents.

In addition to the above, when and as necessary, or when required by the OWNER, the Contractor shall post signs and employ watchmen or flagmen, for the direction of traffic at the site and for excluding at all times unauthorized persons from the work site, for which the Contractor shall be paid no additional compensation.

The Contractor shall be responsible for excluding at all times from the land within the easement areas, all persons not directly connected with the work.

All work occurring on State of Rhode Island highways shall be clearly identified, protected and the public's safety ensured by erection of signs, barriers and all other provisions as outlined in the Manual on Uniform Traffic Control Devices for Streets and Highways; issued by the U. S. Department of Transportation, Federal Highway Administration, 1978; Part VI, Traffic Controls for Streets and Highway Construction and Maintenance Operations.

ARTICLE 46: LOADING

*Pawtucket Housing Authority
St. germain Manor Deck Improvements
Pawtucket, Rhode Island*

No part of the structures involved in this Contract shall be loaded during construction with a load greater than it is calculated to carry with safety. Should any accidents or damage occur through any violation of this requirement, the Contractor will be held responsible under his Contract and bond.

ARTICLE 47: DISPOSAL OF MATERIALS

The materials used in the construction of the work shall be deposited in such manner so they will not endanger persons or the work, and so that free access may be had at any time to all hydrants and gates in the vicinity of the work. The materials shall be kept trimmed up so that as little inconvenience as possible to the public or adjoining tenants is caused.

In case the Contractor fails or neglects to promptly remove all surplus materials, tools, and incidentals after backfilling, leaving the street or surrounding area clean and free of debris, and do the required repaving when ordered, the OWNER may, after 24 hours' notice, cause the work to be done and the cost thereof deducted from any payment due to the Contractor.

ARTICLE 48: FINISHING AND CLEANING UP

In completing his operations, the Contractor shall immediately remove all surplus material, tools, and other property belonging to him, leaving the entire street or surroundings free and clean and in good order, at no additional expense to the OWNER. The Contractor shall exercise special care in keeping the rights-of-way and private lands upon which work is performed free and clean of all debris, and shall remove all tools and other property when they are not in use.

ARTICLE 49: SPIRITUOUS LIQUORS

The Contractor shall neither permit nor suffer the introduction of spirituous liquors upon the work embraced in this Contract, nor the use of the same.

ARTICLE 50: DUST CONTROL

The Contractor shall exercise every precaution and means to prevent and control dust arising out of all construction operations from becoming a nuisance to abutting property owners or surrounding neighborhoods. Dust control shall also protect residents and staff, per best-practices industry standards. Pavements adjoining the project area shall be kept broomed off and washed clean of excess materials wherever and whenever directed. Repeated daily dust control treatment shall be provided to satisfactorily prevent the spread of dust until the permanent engineered cap is constructed and until earth stockpiles have been removed, and all construction operations that might cause dust have been completed. No extra payment will be made for these dust control measures, compensation shall be considered to be included in the prices stipulated for the appropriate items as listed in the bid.

If so directed by the OWNER, the Contractor shall furnish and apply calcium chloride for supplemental control of dust. Calcium chloride shall conform to the requirements of AASHTO M. 144 (ASTM D-98) except that the pellet form and the flake form shall be equally acceptable. Calcium chloride shall be applied only at the locations, at such times and in the amount as may be directed by the OWNER. It shall be spread in such manner and by such devices that uniform distribution is attained over the entire area on which it is ordered placed.

There will be no separate payment for this work. The cost of the work shall be included in the price bid for the various other items of work.

PART III

The rights and obligations of the OWNER under this Contract shall include, but not be limited to the following:

ARTICLE 51: THE OWNER'S AUTHORITY

The OWNER shall give all orders and directions contemplated under this Contract and specifications relative to the execution of the work. The OWNER shall determine the amount, quality, acceptability, and fitness of the several kinds of work and materials that are to be paid for under this Contract and shall decide all questions that may arise in relation to said work and the construction thereof. The OWNER'S estimates and decisions shall be final and conclusive, except as herein otherwise expressly provided. In case any question shall arise between the parties hereto relative to said Contract or specifications, the determination or decision of the OWNER shall be a condition precedent to the right of the Contractor to receive any money or payment for work under this Contract affected by such questions. The OWNER shall decide the meaning and intent of any portion of the specifications and of any plans or drawings where the same may be found to be obscure or be in dispute. Any differences or conflicts in regard to their work that may arise between the Contractor and other contractors performing work for the OWNER shall be adjusted and determined by the OWNER.

ARTICLE 52: ALL WORK SUBJECT TO CONTROL BY THE OWNER

- A. In the performance of the work, the Contractor shall abide by all orders, directions, and requirements of the OWNER, and shall perform all work to the satisfaction of the OWNER, and at such times and places, by such methods, and in such manner and sequence as he may require. The OWNER shall determine the amounts, quality, acceptability, and fitness of all parts of the work. The OWNER shall interpret the drawings, specifications, contract documents, all other documents, and the extra work orders. The OWNER shall also decide all other questions in connection with the work. The Contractor shall employ no plant, equipment, materials, methods or men to which the OWNER objects and shall remove no plant, materials, or equipment or other facilities from the work site without the OWNER'S permission. Upon request, the OWNER will confirm in writing any oral order, direction, requirement, or determination.
- B. Inspectors shall be authorized to inspect all work done and materials furnished. Such inspection may extend to all parts of the work and to the preparation or manufacture of the materials to be used. The presence or absence of an inspector shall not relieve the Contractor from any requirements of the Contract. In case of any dispute arising between the Contractor and the inspector as to materials furnished or the manner in which the work is being executed, the inspector shall have the authority to reject material or suspend work until the question has been decided by the OWNER. The inspector shall not be authorized to revoke, alter, enlarge, relax, or release any requirement of these specifications, or to approve or accept any portion of the work, or to issue instructions contrary to the drawings and specifications. The inspector shall in no case act as foreman or perform other duties for the Contractor, or interfere with the management of the work by the latter. Any advice that the inspector may give the Contractor shall in no way be constructed as binding the OWNER or the Engineers in any way, nor releasing the Contractor from the fulfillment of the terms of the Contract.

ARTICLE 53: THE OWNER'S CONTROL NOT LIMITED

The enumeration in this Contract of particular instances in which the opinion, judgment, discretion or

*Pawtucket Housing Authority
St. germain Manor Deck Improvements
Pawtucket, Rhode Island*

determination of the OWNER shall control or in which work shall be performed to his satisfaction or subject to his approval or inspection, shall not imply that only matters similar to those enumerated shall be so governed and performed, but without exception all the work shall be so governed and performed.

ARTICLE 54: RIGHT OF THE OWNER TO TERMINATE THE CONTRACT

In the event that any of the provisions of this Contract are violated by the Contractor, or any of his subcontractor, the OWNER may serve written notice upon the Contractor and the Surety of its intention to terminate the Contract, such notice to contain the reasons for such intention to terminate the Contract. If within ten days (10) such violation or delay shall not cease and satisfactory arrangement or correction made, the Contract shall, at the expiration of the ten days, cease and immediately serve notice thereof upon the Surety and the Contractor, and the Surety shall have the power to take over and perform the Contract, provided, however, that if the Surety does not commence performing thereof within ten days (10) from the date of mailing to such Surety a Notice of Termination, the OWNER may take over the work and prosecute the same to completion by CONTRACT or force account at the expense of the Contractor, and the Contractor and his Surety shall be liable to the OWNER for any excess cost occasioned the OWNER thereby.

ARTICLE 55: TERMINATION FOR CONVENIENCE

- A. The performance of work under this Contract may be terminated by the OWNER in accordance with this clause in whole, or from time to time in part, whenever the OWNER shall determine that such termination shall be effected by delivery to the Contractor of a Notice of Termination specifying the extent to which performance of work under the Contract is terminated, and the date upon which such termination becomes effective.
- B. After receipt of a Notice of Termination, and except as otherwise directed by the OWNER, the Contractor shall:
 1. Stop work under the Contract on the date and to the extent specified in the Notice of Termination;
 2. Place no further orders or subcontracts for materials, services or facilities except as may be necessary for completion of such portion of the work under the Contract as is not terminated;
 3. Terminate all orders and subcontracts to the extent that they relate to the performance of work terminated by the Notice of Termination;
 4. Assign to the OWNER in the manner, at the times, and to the extent directed by the OWNER, all of the right, title and interest of the Contractor under the orders and subcontracts so terminated. In which case, the OWNER shall have the right, in its discretion, to settle, or pay any or all claims arising out of the termination of such orders and subcontracts;
 5. Settle all outstanding liabilities and all claims arising out of such termination of orders and subcontracts, with the approval or ratification of the OWNER to the extent he may require, which approval or ratification shall be final for all the purposes of this clause;
 6. Transfer title to the OWNER, and deliver in the manner, at the times, and to the extent, if any, directed by the OWNER,
 - a. the fabricated or un-fabricated parts, work in process, completed work, supplies, and other material produced as a part of, or acquired in connection with the performance of the work terminated by the Notice of Termination, and
 - b. The completed or partially completed plans, drawings, information, and other property which, if the Contract had been completed, would have been required to be furnished to the OWNER.
 7. Use his best efforts to sell, in the manner, at the times, to the extent, and at the price or

- prices directed or authorized by the OWNER, any property of the types referred to in (6) above; provided however, that the Contractor
- a. shall not be required to extend credit to any purchaser, and
 - b. may acquire any such property under the conditions prescribed and at a price or prices approved by the OWNER: And, provided further, that the proceeds of any such transfer or disposition shall be applied in reduction of any payments to be made by the OWNER to the Contractor under this Contract or shall otherwise be credited to the price or cost of the work covered by this Contract or paid in other such manner as the OWNER may directed;
8. Complete performance of such part of the work as shall not have been terminated by the Notice to Termination; and
 9. Take such action as may be necessary, or as the OWNER may direct, for the protection and preservation of the property related to this Contract which is in the possession of the Contractor and which the OWNER has or may acquire an interest.
- C. After receipt of a Notice of Termination, the Contractor shall submit to the OWNER his termination claim, in the form and with the certification prescribed by the OWNER. Such claim shall be submitted promptly but in no event later than one year from the effective date of termination, unless one or more extensions in writing are granted by the OWNER upon request of the Contractor made in writing within such one-year period or authorized extension thereof. However, if the OWNER determines that the facts justify such action, he may receive and act upon any such termination claim at any time after such one-year period or extension thereof. Upon failure of the Contractor to submit his termination claim within the time allowed, the OWNER may determine, on the basis of information available to him, the amount, if any, due to the Contractor by reason of the termination and shall thereupon pay to the Contractor the amount so determined.
- D. Subject to the provisions of paragraph (c), the Contractor and the OWNER may agree upon the whole or any part of the amount or amounts to be paid to the Contractor by reason of the total or partial termination of work pursuant to this clause which amount or amounts may include a reasonable allowance for profit on work done: Provided, that such agreed amount or amounts, exclusive of settlement costs, shall not exceed the total contract price as reduced by the amount of payments otherwise made and as further reduced by the contract price or work not terminated. The Contract shall be amended accordingly, and the Contractor shall be paid the agreed amount. Nothing in Paragraph (e) of this clause, prescribing the amount to be paid to the Contractor in the event of failure of the Contractor and the OWNER to agree upon the whole amount to be paid to the Contractor by reason of the termination of work pursuant to this Paragraph (d).
- E. In the event of the failure of the Contractor and the Owner to agree as provided in Paragraph (d) upon the whole amount to be paid to the Contractor by reason of the termination of work pursuant to this clause, the Owner shall determine, on the basis of information available to him, the amount, if any, due to the Contractor the amounts determined as follows:
1. With respect to all contract work performed prior to the effective date of the Notice of Termination, the total (without duplication of any items) of:
 - a. The cost of such work;
 - b. The cost of settling and paying claims arising out of the termination of work under subcontracts or orders provided in Paragraph (b) (5) above, exclusive of the amounts paid or payable on account of supplies or materials delivered or services furnished by the subcontractor prior to the effective date of the Notice of Termination of work under this Contract, which amounts shall be included in the cost on account of which payment is made under (a) above, and;
 - c. A sum, as profit on (a) above, determined by the Owner to be fair and reasonable: Provided, however, that if it appears that the Contractor would have sustained loss on

- the entire Contract had it been completed, no profit shall be included or allowed under this subdivision (iii) and an appropriate adjustment shall be made reducing the amount of the settlement to reflect the indicated rate of loss; and
2. The reasonable cost of the preservation and protection of property incurred pursuant to Paragraph (b) (9); and any other reasonable cost incidental to termination of work under this Contract, including expense incidental to the determination of the amount due to the Contractor as the result of the termination of work under this Contract.
 3. The total sum to be paid to the Contractor under (1) above shall not exceed the total contract price as reduced by the amount of payments otherwise made and as further reduced by the contract price of work not terminated.
 4. Except for normal spoilage, and except to the extent that the Owner shall have otherwise expressly assumed the risk of loss, there shall be excluded from the amounts payable to the Contractor under (1) above, the fair value, as determined by the Owner, of property which is destroyed, lost, stolen, or damaged so as to become undeliverable to the Owner, or to a buyer pursuant to Paragraph (b) (7).
- F. The Contractor shall have the right to dispute under the clause of this Contract entitled "Remedies" from any determination made by the Owner under Paragraph (c) or (e) above, except that, if the Contractor has failed to submit his claim within the time provided in Paragraph (c) above and has failed to request extension of such time, he shall have no such right of appeal. In any case where the Owner has made a determination of the amount due under Paragraph (c) or (e) above, the Owner shall pay to the Contractor the following:
1. if there is no right of appeal hereunder or if no timely appeal has been taken, the amount so determined by the Owner or
 2. If a "Remedies" proceeding is initiated, the amount finally determined in such "Remedies" proceeding.
- G. In arriving at the amount due the Contractor under this clause, there shall be deducted
1. all unliquidated advance or other payments on account theretofore made to the Contractor, applicable to the terminated portion of this Contract,
 2. any claim which the Owner may have against the Contractor in connection with this Contract, and
 3. The agreed price for, or the proceeds of sale of any materials, supplies, or other things kept by the Contractor or sold, pursuant to the provisions of this clause, and not otherwise recovered by or credited by the Owner.
- H. If the termination hereunder be partial, prior to the settlement of the terminated portion of this Contract, the Contractor may file with the Owner a request in writing for an equitable adjustment of the price or prices specified in the Contract relating to the continued portion of the Contract (the portion not terminated by the Notice of Termination) and such equitable adjustment as may be agreed upon shall be made in such price or prices; however, nothing contained herein shall limit the right of the Owner and amounts to be paid to the Contractor for the completion if the continued portion of the Contract when said Contract does not contain an established contract price for such continued portion.

ARTICLE 56: RIGHTS OF ACCESS

Nothing herein contained or shown on the drawings shall be construed as giving the Contractor exclusive occupancy of the work area. The Owner or any other contractors employed by him, the various utility companies, contractors or subcontractors employed by State or Federal agencies, or any other agencies

*Pawtucket Housing Authority
St. germain Manor Deck Improvements
Pawtucket, Rhode Island*

involved in the general project or upon public rights-of-way, may enter upon or cross the area of work or occupy portions of the area as is directed or necessary. When the territory of one contract is the convenient means of access to the other, the Contractor shall arrange his work in such a manner as to permit such access to the other and prevent unnecessary delay to the work as a whole.

ARTICLE 57: RIGHTS-OF-WAY AND SUSPENSION OF WORK

Land and rights-of-way for the purpose of this Contract shall be furnished by the Owner to the extent shown on the drawings; the Owner will use due diligence in acquiring said lands and rights-of-way as speedily as possible. If, however, lands or rights-of-way cannot be obtained before work on the project begins, the Contractor shall begin his work upon such land or rights-of-way as have been previously acquired by the Owner, and no claims for damages whatsoever will be allowed by reason of the delay in obtaining the remaining land and rights-of-way. Should the Owner be prevented or enjoined from proceeding with the work, or from authorizing its prosecution, either before or after the commencement by reason of litigation, or by reason of its inability to procure the lands or rights-of-way for the said work, the Contractor shall not be entitled to make or assert a claim for damages by reason of the said delay, or to withdraw from the Contract except by consent of the Owner. Time for completion of work will be extended to such time as the Owner determines will compensate for the time lost by such delay, such determination to be set forth in writing.

ARTICLE 58: CONFORMANCE WITH DIRECTIONS

The Owner may make alterations in the line, grade, plan, form, dimension, or materials of the work, or any part thereof, either before or after the commencement of construction. Should such alterations diminish the quantity included in any item of work to be done and paid for at a unit price, the Contractor shall have no claim for damages or for anticipated profits on the work that thus may be dispensed with. If they increase the quantity included in any such item, such increase shall be paid for at the stipulated prices.

ARTICLE 59: INTERPRETATION OF THE DRAWINGS AND SPECIFICATIONS

Except for the Contractor's executed set, all drawings and specifications are the property of the Owner. The Owner will furnish the Contractor, without charge, three (3) sets of the drawings and specifications. Additional sets will be furnished upon request, at actual cost of reproduction. Such drawings and specifications are not to be used on other work and those sets in usable condition shall be returned to the Owner upon request at the completion of cessation of the work or termination of the Contract.

The Contractor shall keep one (1) copy of the drawings and specifications at the work site at all times and shall give the Owner and their representatives access thereto. Anything on the drawings and not mentioned in the specifications, or anything in the specifications that is not shown on the drawings shall have the same force and effect as if mentioned in both. In case of conflict or inconsistency between the drawings and the specifications, the specifications shall take precedence. Any discrepancy in the figures and the drawings shall be immediately submitted to the Owner for decision and the decision of the Owner shall be final. In case of differences between small and large-scale drawings, the large-scale drawings shall take precedence.

ARTICLE 60: SUSPENSION OF WORK

- A. The Owner may order the Contractor in writing to suspend, delay, or interrupt all or any part of the work for such period of time as he may determine to be appropriate for the convenience of the Owner.
- B. If the performance of all or any part of the work is, for an unreasonable period of time, suspended,

*Pawtucket Housing Authority
St. germain Manor Deck Improvements
Pawtucket, Rhode Island*

delayed, or interrupted by an act of the Owner in administration of this Contract, or by his failure to act within the time specified in this Contract (or if no time is specified, within a reasonable time), an adjustment shall be made for any increase in the cost of performance of this Contract (excluding profit) necessarily caused by such unreasonable suspension, delay, or interruption and the Contract modified in writing accordingly. However, no adjustment shall be made under this clause for any suspension, delay, or interruption to the extent (1) that performance would have been so suspended, delayed, or interrupted by any other cause, including the fault or negligence of the Contractor or (2) for which an equitable adjustment is provided for or excluded under any other provision of this Contract.

C. No claim under this clause shall be allowed (1) for any costs incurred more than 20 days before the Contractor shall have notified the Owner in writing of the act or failure to act involved (but this requirement shall not apply as to a claim resulting from a suspension order), and (2) unless the claim, in an amount stated, is asserted in writing as soon as practicable after the termination of such suspension, delay or interruption, but not later than the date of final payment under the Contract.

ARTICLE 61: INSPECTION

The authorized representatives and agents of the Owner shall be permitted to inspect all work materials, payrolls, records of personnel, invoices for materials, and other relevant data and records.

PART IV

ARTICLE 62: SUBCONTRACTORS

The Contractor may utilize the services of specialty subcontractors on those parts of the work which, under normal contracting practices, are performed by specialty subcontractors.

The Contractor shall not award work to any subcontractor other than those listed in his bid, without the prior written approval of the Owner, which approval will not be given until the Contractor submits a written statement concerning the proposed award to the subcontractor, which statement shall contain such information as the Owner may require.

The Contractor shall cause appropriate provisions to be inserted in all subcontracts relative to the work, to bind the subcontractors to the contract documents insofar as applicable to the subcontract work and to give the Contractor the same power as regards to terminating any subcontract that the Owner may exercise over the Contractor under any provisions of the contract documents.

Nothing contained in this Contract shall create any contractual relationship between the Owner and any subcontractor.

ARTICLE 63: MUTUAL RESPONSIBILITY OF CONTRACTORS

If, through acts of neglect on the part of the Contractor, any other contractor or any subcontractor shall suffer loss or damage to the work, the Contractor agrees to settle with such other contractor or subcontractor by agreement or arbitration. If such other contractor or subcontractor shall assert any claim against the Owner on account of any damage alleged to have been sustained, the Owner shall notify the Contractor who shall indemnify and save harmless the Owner against any such claim.

ARTICLE 64: ASSIGNMENTS

The Contractor shall not assign the whole or any part of this Contract or any monies due or to become due hereunder without the written consent of the Owner. In case the Contractor assigns all or part of any monies due or to become due under this Contract, the instrument of assignment shall contain a clause

*Pawtucket Housing Authority
St. germain Manor Deck Improvements
Pawtucket, Rhode Island*

substantially to the effect that it is agreed that the right of the assignee in and to any monies due or to become due to the Contractor shall be subject to prior claims of all persons, firms, or corporations for services rendered or materials supplied for the performance of the work called for in this Contract.

ARTICLE 65: SEPARATE CONTRACTS

The Owner reserves the right to let other contracts in connection with the construction of the contemplated work of the project, or contiguous projects of the Owner. The Contractor, therefore, will afford to any such other contractors reasonable opportunity for the introduction and storage of their materials and the execution of their work, will properly connect and coordinate his work with theirs, and will not commit or permit any act which will interfere with the performance of their work.

The Contractor shall coordinate his operations with those of other contractors. Cooperation will be required in the arrangement for storage of materials and in the detailed execution of the work. Failure by the Contractor to keep informed on the progress or defective workmanship by others shall be construed as acceptance by him of the status of the work as being satisfactory for proper coordination with and performance of his own work.

ARTICLE 66: WORK BY OTHERS

The Owner reserves the right to do any other work which may be connected with, or become a part of, or be adjacent to the work embraced by this Contract, at any time, by Contract or otherwise. The Contractor shall not interfere with the work of such others as the Owner may employ, and shall execute his own work in such a manner as to aid in the execution of the work of others as may be required. No backfilling of trenches or excavations will be permitted until such work by the Owner is completed.

PART V

The Contractor agrees that in case of underpayment of wages to any worker on the project under this Contract by the Contractor or any of his subcontractors, the OWNER will withhold from the Contractor out of payments due to him, an amount sufficient to pay such worker the difference between the wages required to be paid under this contract and the wages actually paid such worker for the total number of hours worked, and that the OWNER may disburse such amount so withheld by it for and on account of the Contractor to the employee to whom such amount is due. The Contractor further agrees that the amount withheld pursuant to this article may be in addition to the percentage to be retained by the OWNER pursuant to other provisions of this Contract.

ARTICLE 68: PAYMENT OF EMPLOYEES

The Contractor and each of his subcontractors shall pay each of their employees engaged in the work on the project under this Contract in full, in cash, and not less than once a week, less legally required deductions, provided, that when circumstances render payment in cash unfeasible or impracticable, then payment by check may be effected upon consideration that funds are made available in a local bank and checks may be cashed without charge, trade requirements, or inconvenience to the worker.

ARTICLE 69: NON-DISCRIMINATION IN EMPLOYMENT

In connection with the performance of the work under this Contract, the Contractor agrees not to discriminate against employee because of race, religion, color, or national origin. The aforesaid provisions shall include but not be limited to the following: employment, upgrading, demotion or transfer, recruitment or recruitment advertising, layoff or termination, rate of pay or other forms of compensation and selection for

*Pawtucket Housing Authority
St. germain Manor Deck Improvements
Pawtucket, Rhode Island*

training, including apprenticeship.

ARTICLE 70: APPRENTICES

Apprentices shall be permitted to work only under a bona fide apprenticeship program registered with a State Apprenticeship Council which is recognized by the Federal Committee on Apprenticeship, United States Department of Labor; or if no such Council exists in a State, under a program registered with the Bureau of Apprenticeship, United States Department of Labor.

PART VI

ARTICLE 71: SHOP OR SETTING DRAWINGS

- A. The Contractor shall submit promptly to the Engineer six (6) copies of each shop or setting drawing prepared in accordance with a schedule predetermined by the Contractor. After examination of such drawings by the Engineer, and the return thereof, if re-submission is required, the Contractor shall make such corrections to the drawings as have been indicated and shall furnish the Engineer with six (6)-corrected copies. Regardless of corrections made in or approval given to such drawings by the Engineer, the Contractor will, nevertheless, be responsible for the accuracy of such drawings and for their conformity to the drawings and specifications, unless he notifies the Engineer in writing of any deviations at the time he furnishes the drawings.
- B. Shop drawings of all fabricated work shall be submitted to the Engineer for approval and no work shall be fabricated by the Contractor save at his own risk until approval has been given by the owner. The Special Conditions define the shop drawings required for this project.
- C. The Contractor shall submit all shop and setting drawings on dates sufficiently in advance of requirements to enable the Engineer ample time for reviewing the same, including time for correcting, resubmission and reviewing, if necessary, and no claim for delay will be granted the Contractor by reason of his failure in this respect.
- D. All shop drawings submitted must bear the stamp of the Contractor as evidence that the drawings have been checked by him. Any drawings submitted without this stamp of approval will not be considered and will be returned to the Contractor for resubmissions. If the shop drawings show deviations from the requirements of the Contract Documents because of standard shop practice or other reason, the Contractor shall make specific mention of such variation in his letter of transmittal to the Engineer, in order that an acceptable, suitable action may be taken for proper adjustment; otherwise the Contractor will not be relieved of the responsibility for executing the work in accordance with the Contract Documents even though the shop drawings have been approved.
- E. Where shop drawings are submitted by the Contractor that indicate a departure from the Contract which the Engineer deems to be a minor adjustment in his interest and not involving a change in the contract price or extension of time, the Engineer may approve the drawings but the approval will contain in substance, the following:
 1. "The modification shown on the attached drawings is approved in the interest of the Owner to effect an improvement for the project and is ordered with the understanding that it does not involve any change in the contract price or an extension of time, that it is subject generally to all contract stipulations and covenants; and that it is without prejudice to any rights of the Owner under the contract and bond or bonds."
- F. The approval of the shop drawings will be general and shall not relieve the Contractor from the responsibility for adherence to the Contract, for any error that may exist.
- G. The Contractor agrees to hold the Engineer and the Owner harmless and defend them against

*Pawtucket Housing Authority
St. germain Manor Deck Improvements
Pawtucket, Rhode Island*

damages or claims for damages arising out of injury to others or property of third persons which result from errors on shop, working or setting drawings whether or not they have been approved by the Engineer and/or the Owner.

ARTICLE 72: WORK TO BE ACCOMPLISHED IN ACCORDANCE WITH THE DRAWINGS AND SPECIFICATIONS

The work, during its progress and at its completion, shall conform to the lines and grades shown on the drawings and to the directions given by the Engineer from time to time, subject to such modifications or additions as he shall determine to be necessary during execution of the work; and in no case will any work be paid for in excess of such requirements. The work shall also be accomplished in accordance with the data in these specifications.

ARTICLE 73: CONTRACTOR TO CHECK DIMENSIONS AND SCHEDULES

The Contractor will be required to check all dimensions and quantities shown on the drawings or schedules given to him by the Engineer, and shall notify the Engineer of all errors therein which he may discover by examining and checking the same. The Contractor shall not take advantage of any error or omissions in furnish all instructions should such error or omissions be discovered, and the Contractor shall carry out such instructions as if originally specified.

ARTICLE 74: PLANIMETER

For estimating quantities in which the computation or areas by analytic and geometric methods would be comparatively laborious, it is stipulated and agreed that the calculator or computer shall be considered an instrument of precision adapted to the measurement of such areas.

ARTICLE 75: ADDITIONAL INSTRUCTIONS AND DETAIL DRAWINGS

The Contractor will be furnished additional instructions and detail drawings as necessary to carry out the work included in the Contract. The additional drawings and instructions thus supplied to the Contractor will coordinate with the Contract Documents and will be so prepared that they can be reasonably interpreted as part thereof. The Contractor shall carry out the work in accordance with the additional detail drawings and instructions. The Contractor and the Engineer will prepare jointly a schedule fixing the respective dates for the submission of shop drawings, the beginning of manufacture, testing, and installation of materials, supplies, and equipment, and the completion of the various parts of the work; each schedule to be subject to change from time to time in accordance with the progress of the work.

ARTICLE 76: MATERIALS, SERVICES AND FACILITIES

It is understood that, except as otherwise specifically stated in the Contract Documents, the Contractor shall provide and pay for all materials, labor, tools, equipment, water, light, power, transportation, superintendence, temporary construction of every nature, and all other services and facilities of every nature whatsoever, necessary to protect, execute, complete, and deliver the work within the specified time.

If approved by the Owner, and work necessary to be performed after regular hours, on Saturdays, Sundays, or legal holidays, shall be performed by the Contractor without additional expense to the Owner.

ARTICLE 77: CONTRACTOR'S TITLE TO MATERIALS

No material, supplies, or equipment for the work shall be purchased by the Contractor or any subcontractor, subject to any chattel mortgage or under a conditional sale or other agreement by which an interest therein or in any part thereof is retained by the seller or supplier. The Contractor warrants good title to all material, supplies, and equipment installed or incorporated in the work and further warrants upon completion of all work, to deliver the premises, together with all improvements and appurtenances constructed or placed thereon by him, to the Owner free from any claims, liens, or charges, or encumbrances and further agrees that neither he nor any person, firm or corporation furnishing any material or labor for any work covered by this Contract shall have the right to a lien upon the premises or any improvement or appurtenance thereon.

ARTICLE 78: INSPECTION AND TESTING OF MATERIALS

All materials and equipment used in the construction of the project shall be new and of current manufacture. Testing will be done in accordance with accepted standards and as directed by the Engineer; the laboratory or inspection agency shall be selected by the Engineer. Except as specified elsewhere in these specifications, testing will be part of the Engineering Contract.

All materials and workmanship shall be subject to inspection, examination, and testing by the Engineer at any and all times during manufacture and/or construction and at any and all places where such manufacture and or construction is carried on, to establish conformance with these specifications and suitability for uses intended. Without additional charge, the Contractor shall furnish promptly all reasonable facilities, labor, and materials necessary to make tests so required safe and convenient. He shall also furnish and mill, factory, or other such tests based on the standards and Tentative Standards of the American Society for Testing Materials as required by the Engineer.

ARTICLE 79: DEFECTIVE MATERIALS

No materials shall be laid or used which are known, or may be found to be in any way defective. Any materials found to be defective at the site of work or upon installation shall be replaced by the Contractor at his own expense. Notice shall be given to the Engineer of any defective or imperfect material. Defective or unfit material found to have been laid, shall be removed and replaced by the Contractor with sound and unobjectionable material without additional cost to the Owner.

ARTICLE 80: PATENTS

- A. The Contractor shall hold and save the Owner harmless from liability of any nature or kind, including cost and expenses for, or on account of, and patented or unpatented invention, process, article, or appliance manufactured or used in the Contract, including its use by the Owner.
- B. License and/or royalty fees for the use of a process that is authorized by the Owner must be reasonable, and paid to the holder of the patent, or his authorized agent, directly by the Contractor.
- C. If the Contractor uses any design, device or material covered by letters, patent, or copyright, he shall provide for such use by suitable agreement with the Owner or such patent or copyrighted design, device, or material.
- D. It is mutually agreed and understood that, without exception, the contract prices shall include all royalties, license fees, or costs arising out of the use of such process, design, device, or materials, in any way involved in the work. The Contractor and/or his Surety shall indemnify and save the Engineer and the Owner harmless from all claims for infringement by reason of use of such patented material, device or design, in connection with the work under this Contract, and shall

indemnify the Engineer and the Owner for any cost, expense, or damage which it may be obligated to pay for reason of such infringement at any time during the prosecution of the work.

ARTICLE 81: "OR APPROVED EQUAL CLAUSE"

- A. Whenever a material or article required is specified or shown on the drawings by using the name of the proprietary product or of a particular manufacturer or vendor, any material or article which will perform adequately the duties imposed by the general design may be considered equal and satisfactory providing the material or article so proposed is of equal substance and function in the Owner's opinion. It shall not be purchased or installed without his written approval. In all cases, new material shall be used on the project.
- B. If two or more brands, makes of material, devices or equipment are shown or specified, each should be regarded as the approved equal of the other. Any other brand, make or material, device or equipment, which, in the opinion of the Owner or his authorized agent, is the recognized approved equal of that specified, considering quality, workmanship, and economy of operation, and is suitable for the purpose intended, may be accepted.
- C. If any other material or article is substituted for items shown or specified, the project must result in a savings in the contract price and the Contractor shall submit evidence that the substitute product is equal. Upon approval of the substitute product, the Owner will issue a deductive change order.
- D. If an equipment manufacturer must have a specified period of experience with his product, equipment which does not meet with the specified experience period may, at the option of the owner, be considered if the equipment supplier or manufacturer is willing to provide a bond or cash deposit for the duration of the specified time period which will guarantee replacement of that equipment in the event of failure. Any and all extra work, changes, or costs due to the substitution will be at the expense of the Contractor.

PART VII

#

ARTICLE 82: INSURANCES

The Contractor shall be responsible for maintaining insurance coverage in force for the life of this Contract of the kind and adequate amounts to secure all of his obligations under this Contract and with insurance companies licensed to write such insurance in the State of Rhode Island and acceptable to the Owner. The kinds and amounts of such insurance carried shall not be less than the kinds and amounts of insurance coverage designated in the Special Conditions, and the Contractor agrees that the stipulation herein of the kinds and minimum amounts of coverage or the acceptance by the Owner of certificates indicating the kinds and limits of coverage shall in no way limit the liability of the Contractor to any such kinds and amounts of insurance coverage. All policies issued shall indemnify and save harmless the Owner, the Engineer, and their agents or representatives from any and all claims for damages arising out of the Contract, to either persons or property.

Policies and certificates of all insurances shall be submitted to the Owner by the Contractor in 8 copies prior to preparation of the construction contract. In the event that the form of any policy or certificate of the amount of the insurance of the companies writing the same are not satisfactory to the Owner, the Contractor will be required to obtain proper and acceptable certificates prior to the start of any work. The Contractor shall not cause policies to be canceled or permit them to lapse and all insurance policies shall include a clause to the effect that the policy shall not be subject to cancellation or a reduction in the required limits of liability amounts of insurance until notice has been sent by registered mail to the Owner, stating when, not less than thirty (30) days thereafter, such cancellation or reduction shall be effective. All certificates of insurance shall contain true transcripts from the policy, authenticated by the proper officer of the insurer

*Pawtucket Housing Authority
St. germain Manor Deck Improvements
Pawtucket, Rhode Island*

evidencing in particular, those insure, the extent of the insurance, the location and operations to which the insurance applies the expiration date, and the above-mentioned notice of cancellation clause.

The Contractor shall be responsible for the provision of identical insurance coverages for all his subcontract operations and, in the event that the Contractor's policies do not cover each and every subcontractor, certificates of insurance issued on policies by companies that are acceptable to the Owner covering each and every subcontractor shall be filed under the Owner in 8 copies prior to the commencement of such subcontract operations. All insurance specified in this Contract shall be provided by the Contractor, at no additional expense to the Owner.

PART VIII

ARTICLE 83: COMPENSATION TO BE PAID TO THE CONTRACTOR

- A. The Owner will pay and the Contractor shall receive as full compensation for everything finished and one by the Contractor under this Contract, the unit prices and lump sum prices set opposite the respective items in the accepted bid form herein contained, and payment for approved extra work. The cost of all work required not specifically included in any items herein mentioned, and also for all loss or damage arising out of the nature of the work aforesaid or from the action of the elements, or from any unforeseen obstruction or difficulty encountered in the prosecution of the work and for all risks of every description connected with the work, and for all expenses incurred by or in consequence of the suspension or discontinuance of the work as herein specified, and for assuming all duties, and liabilities, herein required, and for well and faithfully completing the work, and the whole thereof, as herein provided, shall be the responsibility of the Contractor.
- B. The amount of the Contract (accepted bid prices) listed in the bid is based on the estimated quantities and the unit and/or lump sum price as set forth in the bid. It is understood and agreed that the Contractor will accept as payment the actual measured quantities at the unit and/or lump sum price as set forth in the accepted bid.
- C. The estimated quantities given in the bid proposal for the various items of work are given for the purpose of comparing the bids offered for the work under this Contract and if it is found in the performance of the Contract work that any or all of the said estimated quantities are not even approximately correct the Contractor shall have no claim for anticipated profits, or for loss of profit, or for increase in prices as listed in the accepted bid because of the difference between the quantities of the various items of work actually done and the estimated quantities stated in the accepted bid.
- D. No payment or compensation will be made to the Contractor for damages because of hindrance or delay from any cause in the progress of the work, whether such hindrances or delays are avoidable or unavoidable.

ARTICLE 84: PAYMENTS TO CONTRACTOR

- A. At least ten (10) days before each progress payment falls due (but not more often than once a month), the CONTRACTOR shall submit to the ENGINEER a partial payment estimate filled out and signed by the CONTRACTOR covering the WORK performed during the period covered by the partial payment estimate and supported by such data as the ENGINEER may reasonably require. If payment is requested with the ENGINEER'S permission on the basis of materials and equipment not incorporated in the WORK but delivered and suitably stored at or near the site, in accordance with the manufacturer's recommendation and as required by the Owner, the partial payment estimate shall also be accompanied by such supporting data satisfactory to the OWNER

*Pawtucket Housing Authority
St. germain Manor Deck Improvements
Pawtucket, Rhode Island*

as will establish the OWNER'S title to the material and equipment applicable insurance. The ENGINEER will within ten (10) days after receipt of each partial payment estimate either indicate in writing his approval or return the partial payment estimate to the CONTRACTOR indicating in writing his reasons for refusing to approve payment. In the latter case, the CONTRACTOR may make the necessary corrections and resubmit the partial payment estimate. The OWNER will within thirty (30) days of presentation to him of an approved partial payment estimate pay the CONTRACTOR a progress payment on the basis of the approved partial payment estimate assuming an approvable pay estimate is submitted by the stipulated date.

1. **The Owner will retain 5% of the bid value, through the warranty period. After successful completion of the 1 year warranty period, the retainage will be released.**
- B. With each partial payment estimate, the CONTRACTOR shall certify in writing that the project's AS-BUILT DRAWINGS are being maintained accurately and currently. Said certificate shall be signed by the CONTRACTOR'S SUPERINTENDENT and the CONTRACTOR'S ENGINEER or SURVEYOR. Any payment estimate not having said certification attached will be subject to refusal of payment.
- C. Prior to SUBSTANTIAL COMPLETION, the OWNER, with the approval and concurrence of the CONTRACTOR, may use any completed or substantially completed portions of the WORK. Such use shall not constitute an acceptance of such portions of the WORK.
- D. The OWNER shall have the right to enter the premises for the purpose of doing work not covered by the CONTRACT DOCUMENTS. This provision shall not be construed as relieving the CONTRACTOR of the sole responsibility for the care and protection of the WORK or the restoration of any damaged WORK except such as may be caused by agents or employees of the OWNER.
- E. Upon completion and acceptance of the WORK, the OWNER shall issue a certificate attached to the final payment request that the WORK has been accepted by him under the conditions of the CONTRACT DOCUMENTS. The entire balance found to be due the CONTRACTOR, less a five (5%) percent retainage plus other such sums as may be lawfully retained by the OWNER shall be paid to the CONTRACTOR within forty-five (45) days of completion and acceptance of the WORK. The five (5%) percent retainage shall be paid to the CONTRACTOR at the completion of the one-year General Guarantee period. (See GC Article 27.)
- F. The CONTRACTOR will indemnify and save the OWNER or the OWNER'S REPRESENTATIVE harmless from all claims growing out of the lawful demands of SUBCONTRACTORS, laborers, workmen, mechanics, material men, and furnishers of machinery and parts thereof, equipment, tools and all supplies incurred in the furtherance of the performance of the WORK. The CONTRACTOR shall at the OWNER's request furnish satisfactory evidence that all obligations of the nature designated above have been paid, discharged or waived. If the CONTRACTOR fails to do so the OWNER may, after having notified the CONTRACTOR, either pay unpaid bills or withhold from the CONTRACTOR'S unpaid compensation a sum of money deemed reasonably sufficient to pay any and all such lawful claims until satisfactory evidence is furnished that all liabilities have been fully discharged whereupon payment to the CONTRACTOR shall be resumed in accordance with the terms of the CONTRACT DOCUMENTS be construed to impose any obligations upon the OWNER to either the CONTRACTOR, his Surety, or any third party. In paying any unpaid bills of the CONTRACTOR, any payment so made by the OWNER shall be considered as a payment made under the CONTRACT DOCUMENTS by the OWNER to the CONTRACTOR and the OWNER shall not be liable to the CONTRACTOR for any such payments made in good faith.

ARTICLE 85: CHANGE ORDERS

- A. The Owner may, at any time, without notice of the sureties, by written order designated or

*Pawtucket Housing Authority
St. germain Manor Deck Improvements
Pawtucket, Rhode Island*

indicated to be a Change Order, make any change in the work within the general scope of this Contract, including but not limited to changes:

1. In the Specifications (including drawings and designs);
 2. In the method or manner of performance of the work;
 3. In the Owner-furnished facilities, equipment, materials, services, or site; or
 4. Directing acceleration in the performance of the work.
- B. Any other written order or an oral order (which terms as used in this paragraph (b) shall include direction, instruction, interpretation or determination) from the Owner, which causes any such change, shall be treated as a change order under this clause, provided that the Contractor gives the Owner written notice stating the date, circumstances and source of the order and that the Contractor regards the order as a Change Order.
- C. Except as herein provided, no order, statement, or conduct of the Owner shall be treated as a change under this clause or entitle the Contractor to an equitable adjustment hereunder.
- D. If any change, by change order, causes an increase or decrease in the Contractor's cost of, or the time required for, the performance of any part of the work under this Contract, an equitable adjustment shall be made and the Contract modified in writing accordingly: Provided, however, that no claim for any change order (b) above shall be allowed for any costs incurred more than 20 days before the Contractor gives written notice as therein required: and, provided, further, that in case of defective specifications for which the Owner is responsible, the equitable adjustment shall include only increased cost reasonably incurred by the Contractor in attempting to comply with such defective specifications.
- E. If the contractor intends to assert a claim for an equitable adjustment under this clause, he must, within 30 days after receipt of a written change order under (a) above or the furnishing of a written notice under (b) above, submit to the Owner a written statement setting forth the general nature and monetary extent of such claim, unless this period is extended by the Owner. The statement of claim hereunder may be included in the notice under (b) above.
- F. No claim by the Contractor for an equitable adjustment hereunder for any amount shall be allowed unless agreed to by Change Order prior to the work being done.

ARTICLE 86: CHANGES IN THE WORK

No changes in the work covered by the approved Contract Documents shall be made without having prior written approval of the Owner. Charges or credits for the work covered by the approved changes shall be determined by one or more, or a combination of the following methods as the Owner shall direct:

- A. Unit price bid previously approved;
- B. The actual cost of: labor, materials, ownership or rental costs of construction plant and equipment during the use of item on the extra work; power and consumable supplies for the operation of power and equipment; social Security, Old Age, and Unemployment contributions and insurances.
- C. To the cost of "b" above, there shall be added a fixed fee to be agreed upon but not to exceed 15%.
The fee shall be compensation to cover the cost of supervision, overhead, bonds, profits, and any other general expenses.

If a subcontractor performs the work, he shall be entitled to a maximum of 15% as a fixed fee, and the general contractor be entitled to a maximum of 5% (of the cost of the subcontract work excluding subcontractor fixed fee) as a fixed fee.

ARTICLE 87: CLAIMS FOR EXTRA COST

No claims for extra work or cost will be allowed unless the same were done in pursuance of a written

*Pawtucket Housing Authority
St. germain Manor Deck Improvements
Pawtucket, Rhode Island*

order of the Owner as aforesaid, and the claim presented with the first estimate after the changed or extra work is done. When the work is performed under terms specified elsewhere in the Contract, the Contractor shall furnish satisfactory bills, payrolls, and vouchers covering all items of cost and upon the Owner's request, give him full access to the accounts relating thereto.

ARTICLE 88: CHANGES AND MODIFICATIONS

The Owner reserves the right to delete or cancel any item or items or parts thereof as listed in the bid, without recourse by the Contractor. The Owner also reserves the right to add to any item as listed in the bid. The compensation to be paid to the Contractor for such additional extensions, appurtenances, or items shall be made under the applicable items in the bid. If no applicable items are provided in the bid, the compensation to be paid the Contractor shall be set forth under the article entitled "Changes in the Work" as found herein.

ARTICLE 89: ACCEPTANCE OF THE FINAL PAYMENT CONSTITUTES RELEASE

The acceptance of the Final Payment by the Contractor shall be and shall operate as a release to the Owner for all claims and all liability to the Contractor for all things done or furnished in connection with this work and for every act or neglect of the Owner and others relating to or arising out of this work. No payment, however, final or otherwise, shall operate as a release of the Contractor or his Surety from any obligations under this Contract or the performance and payment bond.

The Contractor shall submit a release of liens for vendors and sub-contractors prior to final payment.

End of General Conditions#

SPECIAL CONDITIONS

INDEX TO THE SPECIAL CONDITIONS

<u>ARTICLE NO.</u>	<u>TITLE</u>
1	ENUMERATION OF DRAWINGS, SPECIFICATIONS AND ADDENDA
2	INTERFERENCE WITH EXISTING STRUCTURES
3	CLEANING FINISHED WORK
4	INSURANCES
5	REMEDIES
6	REQUIRED SUBMITTALS
7	TIME FOR COMPLETION AND LIQUIDATED DAMAGES

ARTICLE 1: ENUMERATION OF DRAWINGS, SPECIFICATIONS AND ADDENDA

The following are the Drawings, Specifications, and Addenda that form a part of this Contract, as set forth in Article 1 of the General Conditions of these Contract Documents.

- a. GENERAL CONDITIONS
- b. SPECIAL CONDITIONS
- c. TECHNICAL SPECIFICATIONS
- d. DESIGN PLANS PREPARED BY ENVIRONMENTAL STRATEGIES & MANAGEMENT, INC.

ADDENDA:

No. Dated:

No. Dated:

ARTICLE 2: INTERFERENCE WITH EXISTING STRUCTURES

Whenever it may be necessary to interfere with existing structures needing special care, due notice shall be given to the Owner, and the work shall be done according to his directions. Whenever required, all objects shall be strengthened to meet any additional stress that the work herein specified may impose upon it, and any damage caused shall be thoroughly repaired.

The Contractor shall repair and be responsible for correcting all damages to existing structures at no additional cost to the Owner.

All damaged items of work or items required to be removed and replaced due to construction shall be replaced or repaired by the Contractor to the complete satisfaction of the Owner, and at no additional expense to the Owner.

Under no circumstances will the Contractor interfere in any manner with the normal daily operations of the fire station facility.

ARTICLE 3: CLEANING FINISHED WORK

After the work is completed, all construction areas shall be carefully cleaned free of debris and dirt, rubbish, construction material, and left in first class condition, ready to use. All temporary or excess materials shall be disposed of off-site and the work area left to the satisfaction of the Owner.

ARTICLE 4: INSURANCES

The Contractor shall provide the following insurance in accordance with Article 82 of the General Conditions:

- a. WORKMEN'S COMPENSATION INSURANCE

The Contractor shall provide adequate statutory Workmen's Compensation Insurance, in accordance with M.G.L. c.149, s.34A, for all labor employed on the project who may come within the protection of such laws and shall provide Employer's General Liability Insurance in the amount of \$100,000 for the benefit of his employees not protected by such compensation laws.

- b. CONTRACTOR'S COMPREHENSIVE PUBLIC LIABILITY AND PROPERTY DAMAGE LIABILITY INSURANCE

*Pawtucket Housing Authority
St. germain Manor Deck Improvements
Pawtucket, Rhode Island*

The Contractor shall carry Comprehensive General Liability Insurance with broad form of Contractual General Liability Endorsement attached, providing for a limit of not less than One Million Dollars (\$1,000,000.00) for all damages arising out of bodily injuries to or death of one person, and subject to that limit for each person, a total limit of not less than One Million Dollars (\$1,000,000.00) for all damages arising out of bodily injuries to or the death of two or more persons in any one accident; and Contractor's Comprehensive Property Damage Liability Insurance providing for a limit of not less than One Million Dollars (\$1,000,000.00) for all damages arising out of injury to or destruction of property in any one accident; and subject to a limit of not less than One Million Dollars (\$1,000,000.00) for all damages arising out of injury to or destruction of property during the policy period.

c. OWNER'S PROTECTIVE LIABILITY AND PROPERTY DAMAGE INSURANCE

The Contractor shall provide the Owner an insurance policy written in the name of the Owner, its employees, servants, and agents, and extended to include the interests of Resource Control Associates, Inc.; its employees, and agents; to protect the Owner and the Engineer from any liability which might be incurred against them as a result of any operations of the Contractor or his subcontractors or their employees. Such insurance shall provide for a limit of not less than One Million Dollars (\$1,000,000.00) for all damages arising out of bodily injuries to or the death of any one person, and subject to that limit for each person, a total limit of not less than One Million Dollars (\$1,000,000.00) for all damages arising out of bodily injuries to or the death of two or more persons in any one accident; and a limit of not less than One Million Dollars (\$1,000,000.00) for all damages arising out of injury to or destruction of property in any one accident, and subject to a limit of not less than One Million Dollars (\$1,000,000.00) for all damages arising out of injury to or destruction of property during the policy period.

d. COMPREHENSIVE AUTOMOBILE LIABILITY AND PROPERTY DAMAGE INSURANCE

The Contractor shall carry Comprehensive Automobile Liability Insurance covering all owned vehicles, hired vehicles, or non-owned vehicles in the amount of not less than One Million Dollars (\$1,000,000.00) for all damages arising out of bodily injuries to or the death of any one person; and subject to that limit for each person a total of not less than One Million Dollars (\$1,000,000.00) for all damages arising out of bodily injuries to or the death of two or more persons in any one accident; and Property Damage coverage in the amount of not less than One Million Dollars (\$1,000,000.00) for all damages arising out of injury to or destruction of property.

e. INSURANCE COVERING SPECIAL HAZARDS

Special hazards shall be covered by rider or riders to the Public Liability Insurance and Property Damage Insurance policy or policies herein above required to be furnished by the Contractor, or by separate policies of insurance as follows:

1. Property Damage Liability arising out of the collapse of, or structural injury to any building or structure due to excavation (including borrowing, filling, or back-filling in connection therewith), tunneling, pile driving, cofferdam work, or caisson work, or to moving, shoring, underpinning, razing, or demolition of any building or structure or removal or rebuilding of any structural support thereof.
2. Property Damage Liability for injury to or destruction of property arising, directly or indirectly, from blasting or explosions, however caused, other than explosions of air or steam vessels, piping under pressure, prime movers, machinery or power transmitting equipment.

3. Property Damage Liability for injury or destruction of wires, conduits, pipes, mains, sewers, or other similar property or any apparatus in connection therewith, below the surface of the ground, arising from and during the use of mechanical equipment for the purpose of excavating or drilling within the project limits; injury to or destruction of property at any time resulting there from.
4. The Contractor shall require similar insurance in such amounts to be taken out and maintained by each subcontractor.

f. FIRE INSURANCE

During the progress of work the Contractor shall effect and maintain BUILDER'S RISK INSURANCE ON COMPLETED VALUE FORM against loss by fire, lightning, windstorm, hurricane, cyclone, tornado, hail, explosion, riot, riot attending strike, aircraft, smoke and vehicle damage, vandalism and malicious mischief upon all work in place and all material stored at the building site, whether or not covered by partial payments made by the Owner. This insurance shall be in an amount equal to 100 percent of the insurable portion of the project and shall be for the benefit of the Owner, the Contractor and each Subcontractor as their interest may respectively appear.

If there are any existing adjacent or adjoining structures presently used by the Owner, the risk of the existing adjacent or adjoining structures will be by the Owner.

ARTICLE 5: REMEDIES

REFER TO GENERAL CONDITIONS, ARTICLE 9

ARTICLE 6: REQUIRED SUBMITTALS

The following submittals shall be made in accordance with Article 71 of the General Conditions:

DRAWINGS – Three (3) copies of shop drawings for all materials and equipment to be incorporated into the work shall be submitted to the engineer for review and approval.

ARTICLE 7: TIME FOR COMPLETION AND LIQUIDATED DAMAGES

It is extremely important that the required work be completed within the time frame established by this contract. In the event the contractor fails to deliver the required work within the established schedule, the contractor shall pay liquidated damages in the amount of \$300.00 per calendar day for each day in excess the stated completion date.

END OF SPECIAL CONDITIONS

DIVISION 01 – GENERAL REQUIREMENTS

GENERAL REQUIREMENTS INDEX

SECTION	DESCRIPTION
01000	Summary of Work
01150	Measurement and Payment
01175	Temporary Facilities
01200	As-Built Drawings
01300	Submittals
01400	Quality Controls
01600	Delivery Storage and Handling
066500	Plastic Simulated Wood Trim
077000	Vinyl Corrugated Sheeting

#

SECTION 01000
SUMMARY OF WORK

PART 1.00 - GENERAL

1.01 DESCRIPTION

The Pawtucket Housing Authority St. Germain Manor Deck Improvements project consists of improving fifty-six (56) decks, each consisting of a first and second floor, across four (4) buildings within the residential building complex located at the subject property, 401 Mineral Spring Avenue, Pawtucket, RI. The work encompassed by this contract shall include, but is not limited to the following:

1. Coordinating with the Housing Authority for accessibility to specified buildings and proper staging areas;
2. Mobilization of all applicable equipment staged within the agreed upon location;
3. Coordination and submittals of all required shop drawings to the Engineer for approval on all materials;
4. Remove existing aluminum railing to allow for proposed work and at the conclusion of work, cut to size and reinstall existing rail system;
5. Remove and replace existing canopy fascia with Azek trim;
6. Remove and replace existing trim against building with Azek trim;
7. Wrap existing 2"x8" deck framing with Azek trim;
8. Furnish and install Tuftx vinyl corrugated sheeting;
9. Demobilize from the site following final inspection by the Owner's Representative.

In addition to the proposed bid items described previously, the work includes the following alternate bid items:

1. Wrap existing 6"x6" posts with Azek trim.

1.02 SPECIAL REQUIREMENTS

- A. The Contractor will coordinate the construction schedule with the owner's representative to ensure that access to areas is permitted during the planned time.
- B. The Contractor shall be responsible for removing and protecting any equipment that may interfere with the construction operations. Immediately upon completion of construction activities in a given area, the contractor shall be responsible for returning the area to a pre-construction state satisfactory to the owner's representative.
- C. Do not begin work when inclement weather is forecast to occur prior to the anticipated time of completion of the work item.
- D. The Contractor shall be responsible for verifying the existing and forecasted weather conditions to determine when the conditions are acceptable for removal of the existing roofing system.
- E. The Contractor shall be prepared at all times to protect any uncompleted work from the rapid changes in the weather. If work continues during sudden rains the Contractor shall be responsible to protect the interior of the building.

END OF SECTION#

*Pawtucket Housing Authority
St. Germain Manor Deck Improvements
Pawtucket, Rhode Island*

SECTION 01150
MEASUREMENT AND PAYMENT

PART 1 GENERAL

- 1.1 This section describes the measurement of and the payment for the work to be done under the items listed in the Bid.
- 1.2 Each Unit or Lump-Sum Price stated in the Bid shall constitute full compensation for all labor, equipment, materials and all incidental and appurtenant work required or necessary to satisfactorily complete the specified work in the accordance with the Drawings and Specifications.
- 1.3 Appurtenant items of work shown on the Drawings or specified or required to complete the work but not listed separately under the list of items in the Bid shall be included in the cost of payment under the various applicable bid items of work and no separate payment will be made for such items. It shall be the responsibility of the Contractor to verify any missing or incomplete items.
- 1.4 All existing work removed or damaged by the Contractor's operations shall be replaced to the satisfaction of the Owner at no additional expense to the Owner.
- 1.5 The limits of work shown on the plans shall be considered to be the pay limits. If the Contractor carries work on beyond the designated limits without prior approval of the Owner or the Owner's Representative, then the Contractor shall restore that additional area at his own expense. Any work conducted beyond the specified pay limits, unless approved in writing by the Owner, shall not be measured for payment.
- 1.6 Estimated quantities of work or any other construction under this contract may change depending on actual field conditions. Any increase or decrease in quantities shall in no way affect this Contract, the unit price of the work item or give cause for claims or liabilities for damages.
- 1.7 Proposed items of work under this Contract are given for use in comparing bids and the right is especially reserved by the Owner to diminish them as may be deemed necessary or desirable by the Owner to meet available funding. Such changes to the proposed items of work shall in no way affect this Contract, nor give cause for claims or liabilities for damages.
- 1.8 The Owner has the right to delete any item or items from the Contract.
- 1.9 All unit prices and bids shall be representative of the work to be undertaken or of items to be supplied. Unbalanced bids shall not be permitted and may be basis for disqualification of the bid.
- 1.10 All work for this project is to be done in accordance with the latest edition of International Building Code as amended, and the specifications accompanying these Contract Documents. Standard details for this project are the details accompanying these Contract Documents.
- 1.11 The Contractor shall include the cost of other indirect and miscellaneous costs in his/her submitted bid items.

PART 2 MEASUREMENT AND PAYMENT

2.01 Bid Item 1. Deck Improvements

A. Measurement:

Deck Improvements shall be measured by a per each amount. The work measured under this item shall include but not be limited to, coordination with the Housing Authority and the Owner's Representative on shop drawing submittals and associated work hours and staging areas, post proper signage of possible hazards on site during construction, wrap of existing deck framing with approved waterproof trim, remove the existing aluminum railing to allow for adequate spacing for the proposed work, furnish and install new corrugated vinyl sheeting beneath the second floor decking, remove and replace existing fascia, cut to size and reinstall aluminum rail system, all of which to be included in both the first and second levels of each deck, in accordance to design plans and specifications, returning the work areas to original site conditions upon completion following final inspection of the Owner's Representative, as well as all associated activities, completed and accepted by the Engineer.

B. Payment:

The accepted quantity for Bid Item 1 shall be paid for at the contract Price of Each, complete and accepted, including labor, materials, tools, equipment and all other incidentals necessary to complete the work in accordance with the plans, as directed by the Engineer and to the satisfaction of the Owner.

PART 3 MEASUREMENT AND PAYMENT – Add Alternate Bid Items

3.01 Bid Item 1. Wrap 6"x6" Post

A. Measurement:

Wrap 6"x6" Post shall be measured by a per each amount. The work measured under this item shall include but not be limited to, furnish and wrap the existing 6"x6" pressure treated posts on the first and second levels of each deck proposed for improvements, in accordance to design plans and specifications, as well as all associated activities, completed and accepted by the Engineer.

B. Payment:

The accepted quantity for Alternate Bid Item 1 shall be paid for at the contract Price of Each, complete and accepted, including labor, materials, tools, equipment and all other incidentals necessary to complete the work in accordance with the plans, as directed by the Engineer and to the satisfaction of the Owner.

END OF SECTION 01150

SECTION 01175
TEMPORARY FACILITIES

PART 1.00 - GENERAL

1.01 **WORK INCLUDED**

- A. The Contractor shall provide all temporary facilities enumerated herein or required for the proper completion of the work.
- B. Temporary facilities shall include but not limited to:
 - Sanitary Facilities
 - Electrical power
 - Lockable trailer/storage container

PART 2.00 - FACILITIES

2.01 **SANITARY FACILITIES**

- A. Adequate sanitary conveniences for use of workman on the premises, properly secluded from public observance, shall be provided and maintained by the Contractor, in accordance with local and state health requirements, and in such a manner and at such points as shall be approved by these authorities, and their use shall be strictly enforced. Sanitary waste shall be treated and disposed of in a manner satisfactory to the Owner and the local and state authorities. Under no circumstances shall sanitary wastes be allowed to flow on the surface of the ground.

2.02 **ELECTRICAL POWER**

- A. The Contractor shall provide all temporary electrical power required to operate equipment for the duration of the Contract.
- B. The securing of all permits and approvals from the regulating utility companies shall be the responsibility of the Contractor. All unauthorized sources of power, such as from neighboring homes, shall be prohibited.

2.03 **LOCKABLE TRAILER/STORAGE CONTAINER**

- A. The Contractor shall provide a lockable trailer/storage container to safely secure all new equipment and materials.
- B. The Engineer/Owner will designate the storage location.

2.04 **REMOVALS**

- A. The Contractor shall remove and properly dispose of all temporary facilities at the satisfactory completion of the Contract.
- B. All sites utilized for temporary facilities shall be restored to a condition satisfactory to the Owner.

END OF SECTION 01175

#

SECTION 01200
AS-BUILT DRAWINGS

PART 1.00 - GENERAL

1.01 WORK INCLUDED

- A. The work under this Section shall include the transmittal to the Engineer of all applicable data relative to as-built conditions as may be required by the Engineer.

PART 2.00 - PRODUCTS

- 2.01 As-built information as specified.

PART 3.00 - EXECUTION

3.01 MARKED-UP PRINTS

- A. The Engineer shall provide the Contractor with an extra set of prints of the Drawings to be used for indicating the locations, elevations and other as-built conditions.
- C. The marked-up prints shall be kept up to date on a daily basis and shall be available for the Owner's inspection at all times. Any inaccuracies or incomplete information shall be correct immediately.
- D. They shall be kept in a safe location by the Contractor, or at the Contractor's option, in the offices of the Owner.
- E. All markings on the prints shall be done neatly with a red pencil.
- F. After review of As-Built by the Engineer and an approval is given, the Engineer shall transmit the revised plans to the Owner via AutoCAD.

END OF SECTION#



SECTION 01300
SUBMITTALS

PART 1 – GENERAL

1.00 REQUIREMENTS INCLUDED

- A. Submit Product Data, Samples and Certifications concurrently as required by Contract Documents and as reasonably requested by the Engineer.
- B. Prepare and submit to the Engineer no later than ten (10) calendar days after receipt of Notice to Proceed (NTP), a list of submittals required by each Specification Section in the Contract Agreement. Submit in accordance with this Section.
- C. Designate in schedule data dates for submission and review of shop drawings, product data and samples, and the date of return.

1.01 PRODUCT DATA

- A. Preparation
 - 1. Annotate each sheet to clearly identify specific product or part installed and specific data applicable to installation.
 - 2. Show performance characteristics and capacities.
 - 3. Show dimensions and clearances required.
 - 4. Indicate specified finish.
 - 5. Indicate only those sheets, which are pertinent to specific product(s) with product clearly identified.
- B. Manufacturer's standard schematic drawings and documents.
 - 1. Modify drawings and diagrams to delete information, which is not applicable to the Work.
 - 2. Supplement standard information to provide information, which is applicable to the Work.

1.02 SAMPLES

- A. Provide a minimum of three (3) office samples, or as otherwise indicated in the Technical Specifications, of sufficient size to clearly illustrate:
 - 1. Functional characteristics of the product, with integrally related parts and attachment devices.
 - 2. Full range of color, texture, and pattern.
 - 3. Samples shall be referenced to applicable section of the specifications.
 - 4. Sample of selected color, texture or finish is to be provided on 4" x 4" (or as appropriate) sample chip. Record sample to match actual material installed.

1.03 MANUFACTURER'S CERTIFICATION OF MATERIALS AND EQUIPMENT

- A. Certification is required for the following systems:
 - 1. Systems requiring certification will be specified in each of the Divisions of the Technical Specifications.

*Pawtucket Housing Authority
St. Germain Manor Deck Improvements
Pawtucket, Rhode Island*

1.04 CONTRACTOR REVIEW

- A. Contractor shall review all submittals prior to transmittal to the Engineer.
 - 1. The Contractor shall consecutively number all shop drawings and product data transmittals. Re-submittals would have the same number of the previous submittal followed by the suffix "A, B, C etc."
 - 2. The transmittal is to contain the project number and the applicable specification section for each product represented on the transmittal.
- B. Apply Contractor's stamp to submittals, initialed or signed by authorized person and dated, certifying: review of submittal, verification of products, field measurements and field construction criteria, and coordination of information within submittal with requirements of Work and the Contract Documents.
- C. Submittals without Contractor's stamp or submittals that, in the Engineer's opinion are incomplete, contain numerous errors, or have not been checked or have only been checked superficially, will be returned without comments. Delays resulting there from shall be solely the Contractor's responsibility.
- D. Clearly note proposed deviations from the Contract Documents on submittals. Submit listing identifying deviations in a format acceptable to the Engineer.
- E. Contractor shall be responsible to ensure quantities and dimensions shown on submittals comply with the requirements of the Contract Documents.

1.05 SUBMISSION REQUIREMENTS

- A. Make submittals promptly in accordance with approved schedule and in such sequence as to cause no delay in the Work. Submittals by Contractor shall be made only through the Engineer.
- B. Number of submittals required:
 - 1. Shop Drawings: Submit one (1) reproducible transparency (sepia) and three (3) opaque reproductions (prints) in addition to what the Contractor will require back.
 - 2. Product Data: Submit copies Contractor requires, plus three (3) originals that will be retained by the Engineer.
 - 3. Samples: Submit two (2) samples of each material or the number required in each specification section.
- C. Submittals shall contain:
 - 1. Date of submission and dates of any previous submissions.
 - 2. Project title and number.
 - 3. Contract identification number.
 - a. The names of:
 - b. Contractor.
 - c. Subcontractor.
 - d. Supplier.
 - e. Manufacturer.
 - 4. Identification of the product, with the specification section number.

*Pawtucket Housing Authority
St. Germain Manor Deck Improvements
Pawtucket, Rhode Island*

5. Field dimensions, clearly identified as such.
6. Relation to adjacent or critical features of the Work or Materials.
7. Applicable standards, such as ASTM or Federal Specification numbers.
8. Identification of deviations from Contract Documents and justification.
9. Identifications of revisions on re-submittals.
10. Additional information as required by Contract Documents.
11. An 8-in.x 3-in. blank space for Contractor and Engineer stamps.

D. Contractor's responsibility for deviations in submittals from requirements of Contract Documents is not relieved by Engineer and/or Engineer's review of submittals

E. Numbering system established by the Contractor shall be agreeable to Engineer.

1.06 RESUBMISSION REQUIREMENTS

A. Make any corrections or changes in the submittals required by the Engineer, mark number of submission, and resubmit as required until approved.

B. Product Data:

1. Revise initial data, and resubmit as specified for the initial submittal.
2. Indicate any changes which have been made other than those requested by the Engineer.
3. Mark number of submission and resubmit until accepted.

C. Samples: Submit new samples as required for initial submittal. Remove samples, which are "rejected" or designated "resubmit."

1.07 ENGINEER REVIEW RESPONSIBILITIES

A. The Engineer shall review submittals with responsible promptness in accordance with the requirements of the Project Manual.

B. Affix stamp and initials or signature, and indicate requirements for revisions and re-submittal, if any.

C. Return submittals to Contractor and Owner for distribution, or for resubmission within fourteen (14) days of original receipt.

1.08 SUBMITTAL LIST

A. Shop Drawings

1. White 1"x6" Azek Trim;
2. Intext Millwork Liberty Extruded and Routed Cellular Rail System;
3. Tuftex Vinyl Corrugated Sheeting.

B. Permits

END OF SECTION 01300

*Pawtucket Housing Authority
St. Germain Manor Deck Improvements
Pawtucket, Rhode Island*

SECTION 01400
QUALITY CONTROL

PART 1 – GENERAL

1.00 RELATED DOCUMENTS

- A. Documents related to this section include, but are not limited to, General Conditions, Special Conditions, Bidding Documents, Technical Specifications and Drawings

1.01 QUALITY CONTROL

- A. The contractor shall be:
1. acceptable to the owner
 2. acceptable and approved by the material manufacturers / suppliers
- B. Any deficiencies noted during construction inspection must be corrected by the contractor and approved by the owner at no additional expense to the owner

1.02 FIELD QUALITY CONTROL

- A. The existing dimensions shown on the plans are approximated and used to describe the scope of work. The contractor shall verify all existing dimensions.
- B. Any discrepancies found must be submitted to the Engineer in writing.

1.03 RANDOM SAMPLING

- A. During the course of work, the owner / engineer may at their discretion secure samples of materials being used from containers at the job site and submit them to an independent laboratory for testing and comparison to specified materials.
- B. If test results prove that a material is not functionally equal to specified material:
1. The Contractor shall pay for all testing
 2. All materials having failed testing that have been installed will be removed and replaced with specified materials at no additional expense to the owner
 3. All materials having failed testing not installed will be removed from the job site and replaced with specified materials at no additional expense to the owner

PART 2 – PRODUCTS

2.00 GENERAL

- A. Comply with quality control, references, specifications and manufacturer's data. Where a conflict exists, the more stringent requirements govern.

PART 3 – EXECUTION

3.00 SUBMITTALS

- A. Provide property owner/engineer a letter from the material manufacturer indicating that the applicator is approved to install their products and will provide warranty for this installation

END OF SECTION 01400

*Pawtucket Housing Authority
St. Germain Manor Deck Improvements
Pawtucket, Rhode Island*

SECTION 01600
DELIVERY, STORAGE AND HANDLING

PART 1 – GENERAL

1.00 RELATED DOCUMENTS

- A. Documents related to this section include, but are not limited to, General Conditions, Special Conditions, Bidding Documents, Technical Specifications and Drawings

PART 2 - DELIVERY, STORAGE AND HANDLING

2.00 DELIVERY OF MATERIALS

- A. Deliver materials to the job-site in new, dry, unopened and well marked containers showing product and manufacturer's name
- B. Deliver materials in sufficient quantity to allow continuity of work

2.01 STORAGE OF MATEIALS

- A. Remove plastic packing shrouds. Cover all stored materials with canvas tarp top to bottom. Secure tarps
- B. Ground Storage: store materials in a secure location as directed by owner/engineer to avoid interference with normal operations of the site

2.02 MATERIAL HANDLING

- A. Handle all materials on site to avoid bending, tearing, or other damage during transportation and installation
- B. Material handling equipment shall be selected and operated so as not to damage existing construction. Do not operate or situate material handling equipment in locations that will hinder smooth flow of vehicular or pedestrian traffic.
- C. Handle all materials in accordance with manufacturer's guidelines

2.03 ENVIRONMENTAL REQUIREMENTS

- A. Do not work when environmental conditions exceed the material manufacturer's guidelines
- B. Protect all unfinished work from rain, water or other harsh environmental conditions
- C. Any damage to materials or existing construction caused by the contractor's failure to protect such shall be repaired or replaced at no additional expense to the owner

END OF SECTION 01600



SECTION 06 65 00 – Simulated Wood Trim

Plastic Simulated Wood Trim

PART 1 GENERAL

1.1 SECTION INCLUDES

- A. Cellular PVC trim boards for:
 - 1. Corner boards
 - 2. Soffits
 - 3. Fascia
 - 4. Battens
 - 5. Door pilasters
 - 6. Frieze boards
 - 7. Rake boards
 - 8. Architectural millwork
 - 9. Door trim
 - 10. Window trim
 - 11. Wainscoting
 - 12. Pergolas
 - 13. Cupolas
 - 14. Porch Ceilings
 - 15. Arbors
 - 16. Fencing
 - 17. Column Wraps
 - 18. Skirtboards
 - 19. Water tables
 - 20. Pilasters

1.2 RELATED SECTIONS

- A. Section 06 11 16 – Mechanically Graded Lumber
- B. Section 06 20 00 – Finish Carpentry
- C. Section 06 30 00 – Exterior Carpentry
- D. Section 06 40 00 – Architectural Woodwork
- E. Section 06 43 16 – Wood Railings
- F. Section 06 64 00 - Plastic Paneling
- G. Section 06 65 00 – Plastic Simulated Wood Trim
- H. Section 06 66 00 – Custom Ornamental Simulated Woodwork
- I. Section 09 90 00 – Painting and Coating

1.3 REFERENCES

- A. ASTM D792 - Density and Specific Gravity of Plastics by Displacement.
- B. ASTM D570 - Water Absorption of Plastics.
- C. ASTM D638 - Tensile Properties of Plastics.
- D. ASTM D790 - Flexural Properties of Unreinforced and Reinforced Plastics and Electrical Insulating Materials.
- E. ASTM D1761 - Mechanical Fasteners in Wood.
- F. ASTM D5420 - Standard Test Method for Impact Resistance of Flat, Rigid Plastic Specimen by means of a Striker Impacted by a Falling Weight.
- G. ASTM D256 - Determining the Pendulum Impact Resistance of Plastics.
- H. ASTM D696 - Coefficient of Linear Thermal Expansion of Plastics Between -30°C and 30°C with a Vitreous Silica Dilatometer.
- I. ASTM D635 - Rate of Burning and/or Extent and Time of Burning of Plastics in a Horizontal Position.
- J. ASTM E84 - Surface Burning Characteristics of Building Materials.
- K. ASTM D648 - Deflection Temperature of Plastics Under Flexural Load in the Edgewise Position.
- L. ASTM D3679 - Standard Specification for Rigid Poly Vinyl Chloride (PVC) Siding.

1.4 SUBMITTALS

- A. General: Submit under provisions of Section 01 30 00 – Administrative Requirements.
- B. Product Data: Manufacture's data sheets on each product to be used, including:
 - 1. Preparation instructions and recommendations.
 - 2. Storage and handling requirements and recommendations.
 - 3. Installation instructions and methods.
 - 4. Code compliance reports.
- C. LEED Submittals: Provide documentation of how the requirements of Credit will be met:
 - 1. List of proposed materials demonstration that each material was extracted, harvested or recovered, as well as manufactured within 500 miles of the project site.
- D. Samples: For each product specified, two samples, minimum size 6 inches long, representing actual product, color, finish.

1.5 QUALITY ASSURANCE

- A. Manufacturer Qualifications: Manufacturer with a minimum of 15 years producing PVC trim products.
- B. Installer Qualifications: Installer with a minimum of 3 years experience with the installation of PVC trim products.
- C. Regulatory Requirements: Check with Local Building Code for installation requirements.
- D. Allowable Tolerances:
 - 1. Variation in component length: -0.00 / +1.00"
 - 2. Variation in component width: $\pm 1/16$ "

3. Variation in component thickness: $\pm 1/16''$
4. Variation in component edge cut: $\pm 2^\circ$
5. Variation in Density -0% + 10%

- E. Mock-Up: Provide a mock-up for evaluation of surface preparation techniques and application workmanship.
1. Finish areas designed by Architect.
 2. Do not proceed with remaining work until workmanship, color, and sheen are approved by architect.
 3. Refinish mock-up area as required to produce acceptable work.
 4. Accepted mock-ups shall be comparison standard for remaining work.

1.6 DELIVERY, STORAGE AND HANDLING

- A. Trim materials should be stored on a flat and level surface on a full shipping pallet. Handle materials to prevent damage to product edges and corners.
- B. Store materials under a protective covering to prevent jobsite dirt and residue from collecting on the boards.

1.7 WARRANTY

- A. Provide manufacturer's Limited Lifetime warranty against defects in manufacturing that cause the products to rot, corrode, delaminate, or excessively swell from moisture.

PART II PRODUCTS

2.1 MANUFACTURES

- A. Acceptable products: AZEK® Trimboards manufactured by The AZEK® Company, which is located at: 888 N Keyser Ave Scranton, PA 18508
- B. Substitutions: Not permitted
- C. Requests for substitutions will be considered in accordance with provisions of Section 01 60 00 – Product Requirements

2.2 MATERIALS

- A. PVC: Free foam cellular PVC material with a small cell microstructure and density of .55 grams/cm³.
 - Material shall have a minimum physical and performance properties specified in the following Section C.
- C. Performance and physical characteristic requirements:

Property	Units	Value	ASTM Method
PHYSICAL			
Density	g/cm ³	0.55	D 792
Water Absorption	%	0.15	D 570
MECHANICAL			
Tensile Strength	psi	2256	D 638
Tensile Modulus	psi	144,000	D 638
Flexural Strength	psi	3329	D 790
Flexural Modulus	psi	144,219	D 790
Nail Hold	Lbf/in of penetration	35	D 1761

Property	Units	Value	ASTM Method
Screw Hold	Lbf/in of penetration	680	D 1761
Staple Hold	Lbf/in of penetration	180	D 1761
Gardner Impact	in-lbs	103	D5420
Charpy Impact (@23°C)	ft-lbs	4.5	D256
THERMAL			
Coefficient of Linear Expansion	in/in/°F	3.2 x 10-5	D 696
Burning Rate	in/min	No burn when flame removed	D 635
Flame Spread Index	--	25	E 84
Heat Deflection Temp 264 psi	°F	150	D 648
Oil Canning (@140°F)	°F	Passed	D 648

2.3 SIMULATED WOOD TRIM

- A. PVC Trimboard: AZEK® Trimboard with Sealed Edge, designed with a natural appearance to compliment fiber cement and natural cedar.
1. Size:
 - a. Nominal Width:
 - 1) 2 inches
 - 2) 4 inches
 - 3) 5 inches
 - 4) 6 inches
 - 5) 8 inches
 - 6) 10 inches
 - 7) 12 inches
 - 8) 16 inches
 - b. Nominal Thickness:
 - 1) 5/8 inch (5/8 inch actual size)
 - 2) 1 inch (3/4 inch actual size)
 - 3) 5/4 inch (1 inch actual size)
 - 4) 6/4 inch (1-1/4 inch actual size)
 - 5) 8/4 inch (1-1/2 inch actual size)
 - c. Length:
 - 1) 12 feet
 - 2) 18 feet
 2. Finish:
 - a. Traditional/Smooth finish
 - b. Reversible with Traditional (Smooth)/Frontier (Woodgrain) finish
- B. Sheet Board: AZEK® Traditional (Smooth)/Frontier (Woodgrain) finish Sheet. For use as sheet materials or to create columns and gingerbread millwork.
1. Size:
 - a. Width/Length:
 - 1) 4 foot by 8 foot
 - 2) 4 foot by 10 foot
 - 3) 4 foot by 12 foot
 - 4) 4 foot by 18 foot
 - 5) 4 foot by 20 foot
 - b. Thickness:
 - 1) 3/8 inch
 - 2) 1/2 inch
 - 3) 5/8 inch

- 4) 3/4 inch
 - 5) 1 inch
 - 6) 1-1/4 inch
 - 7) 1-1/2 inch
2. Finish:
- a. Smooth/Traditional finish
 - b. Reversible with Traditional (Smooth)/Frontier (Woodgrain) finish
- C. PVC Cornerboard: AZEK® Corners: Folded, 90-degree, one-piece assembly produced with a Traditional or Frontier appearance to compliment fiber cement and natural cedar.
1. Size:
- a. Nominal Corner Size:
 - 1) 4 inches
 - 2) 6 inches
 - 3) 8 inches
 - b. Nominal Thickness:
 - 1) 5/4 inch (1 inch actual size)
 - c. Length:
 - 1) 10 feet
 - 2) 20 feet
2. Finish:
- a. Traditional (Smooth)
 - b. Frontier (Woodgrain)
- D. PVC Bead Board: AZEK® Beadboard: Tongue-and-Groove and Beaded Sheets.
1. Size:
- a. Thickness/Width/Length:
 - 1) Regular 5/8 inch by 4 Inches (Actual size 5/8 inch by 3-1/2 inches). Length 18 feet.
 - 2) Regular 1/2 inch by 6 inches (Actual size 1/2 inch by 5-1/2 inches). Length 18 feet.
 - 3) Regular 1 inch by 6 inches (Actual 3/4 inch by 5 1/2 inch). Length 18 feet.
 - 4) Sheet 1/2 inch by 4 feet (Actual size 1/2 inch by 48-1/8 inches) Length 8 feet.
 - 5) 1/2 inch by 4 Inches (Actual size 1/2 inch by 3-1/2 inches). Length 18 feet.
 - 6) 1/2 inch by 6 inches (Actual size 1/2 inch by 5-1/2 inches). Length 18 feet.
 - 7) 1 inch by 6 inch (Actual size 3/4 inch by 5 1/2 inches). Length 18 feet.
 - 8) WP4 T & G board 3/4 inch by 5-7/16 inch. Length 18 feet.
 - 9) Shiplap 1 inch by 6 inches (Actual size 3/4" by 5 1/2"). Length 18'
 - 10) Shiplap 1 inch by 8 inches (Actual size 3/4" by 7 1/4"). Length 18'
2. Finish:
- a. Traditional/Smooth finish.
- E. Mouldings: AZEK® Mouldings designed to complement exterior trim.
1. Crowns:
- a. 3 inches.
 - b. 4 Inches.
 - c. 5 inches.
 - d. 6 inches.
 - e. 8 inches.
 - f. Bed Mould.
 - g. Rams Crown.
 - h. Solid Crown.
 - i. Imperial Rake Crown.
 - j. Crosshead Pediment.
2. Casings:
- a. Base Cap.
 - b. Brick Mould.
 - c. Back Band.
 - d. Rake Moulding.

- e. Adams Casing.
- f. Crosshead Pediment.
- g. Fluted/Reeded Casing.
- 3. Cove:
 - a. Quarter Round.
 - b. Bed Moulding.
 - c. Baluster Moulding.
 - d. Scotia Cove.
 - e. Cove Moulding
- 4. Sill:
 - a. Sill.
 - b. Sill Nose.
 - c. Heavy Sill.
 - d. Sub Sill Nose.
 - e. Historic Sill.
 - f. Large Historic Sill.
 - g. Window Sill Nose
- 5. Specialty:
 - a. Drip Cap.
 - b. Shingle Mould.
 - c. Garage Door Thermostop.
 - d. Water Table.
 - e. Beaded Cap.
 - f. Panel Mould.
 - g. Wainscot Cap.
- 6. J-Channel Series.
 - 1) J-Brick
 - 2) 4" J-Casing
 - 3) 6" J-Casing
 - 4) 4" QuickCorner
 - 5) 6" QuickCorner
- 7. Length:
 - a. 12 feet.
 - b. 16 feet.
 - c. 18 feet.
- 8. Finish:
 - a. Smooth finish.

2.4 SIMULATED WOOD TRIM

- A. PVC Trimboard: AZEK® Rabbeted Trimboard, designed with 3/4 inch pocket to accommodate any siding product including fiber cement, cedar, hardboard and vinyl.

- 1. Size:
 - a. Nominal Width:
 - 1) 4 inches
 - 2) 6 inches
 - 3) 8 inches
 - b. Nominal Thickness:
 - 1) 5/4 inch (1 inch actual size)
 - c. Length:
 - 1) 18 feet
- 2. Finish:
 - a. Traditional/Smooth finish
 - b. Frontier (Woodgrain) finish

B.

- C. PVC Cornerboard: AZEK® Rabbeted Corners. Folded 90 degree one piece corner assembly designed with 3/4 inch pocket to accommodate any siding product including fiber cement, cedar, hardboard and vinyl.

- 1. Size:
 - a. Nominal Corner Width:

- 1) 4 Inches
 - 2) 6 inches
 - b. Nominal Thickness:
 - 1) 5/4 inch (1 inch actual size).
 - c. Length:
 - 1) 10 feet.
 - 2) 20 feet.

- D. PVC Skirtboard: AZEK® 1-Piece Skirtboard. Precut trim providing grade clearance and starter strip for fiber cement sidings as well as composite sidings.
 - 1. Size:
 - a. Nominal Width:
 - 1) 5/4 inch x 4 inches
 - 2) 5/4 inch by 6 inches
 - 3) 5/4 inch by 8 inches
 - 4) 1 inch by 4 inches
 - 5) 1 inch by 6 inches
 - 6) 1 inch by 8 inches
 - 7) 1 inch by 10 inches
 - b. Length:
 - 1) 18 feet.
 - 2. Finish:
 - a. Traditional/Smooth finish.
 - b. Frontier/Woodgrain finish.

- E. PVC Skirtboard: AZEK® Universal Skirt Board, A two-piece reversible trimboard with integrated z-flashing and starter.
 - 1. Size:
 - a. Nominal Width:
 - 1) 5/4 inch by 6 inches
 - 2) 5/4 inch by 8 inches
 - 3) 5/4 inch by 10 inches
 - b. Length:
 - 1) 18 feet.
 - 2. Finish:
 - a. Traditional/Smooth finish.
 - b. Frontier/Woodgrain finish.

- F. PVC Bandboard/Skirtboard: AZEK® Integrated Drip Edge, A two-piece reversible trimboard with integrated z-flashing.
 - 1. Size:
 - a. Nominal Width:
 - 1) 5/4 inch by 6 inches
 - 2) 5/4 inch by 8 inches
 - 3) 5/4 inch by 10 inches
 - b. Length:
 - 1) 18 feet.
 - 2. Finish:
 - a. Traditional/Smooth finish.
 - b. Frontier/Woodgrain finish.

- G.

- H. PVC Columnwrap: AZEK® one-piece column wraps.
 - 1. Size:
 - a. Nominal Width:
 - 1) 4 inches by 4 inches (inside dimensions 3-3/4 inches)
 - 2) 6 inches by 6 inches (inside dimensions 5-3/4 inches)
 - 3) 8 inches by 8 inches (inside dimensions 7-1/2 inches)
 - b. Length:

- 1) 8 feet 6 inches
 - 2) 10 feet
 - c. Thickness:
 - 1) 1/2 inch
- 2. Finish:
 - a. Traditional/Smooth finish.

2.5 SIMULATED WOOD TRIM

- A. Paintable PVC Trimboard: AZEK® PaintPro® Trimboard, designed with a natural appearance to compliment fiber cement, engineered wood, natural cedar and is engineered to be painted.
 - 9. Size:
 - a. Nominal Width:
 - 1) 4 inches
 - 2) 6 inches
 - 3) 8 inches
 - 4) 10 inches
 - 5) 12 inches
 - b. Nominal Thickness:
 - 1) 1 inch (3/4 inch actual size)
 - 2) 5/4 inch (1 inch actual size)
 - c. Length:
 - 1) 16 feet
 - 10. Finish:
 - a. Reversible with Traditional (Smooth)/Frontier (Woodgrain) finish
 - b. Painting
 - 1) Must be painted within 180 days of UV exposure
 - 2) For lighter colors with a Light Reflective Value (LRV) 55 or greater: paint must be 100% acrylic latex.
 - 3) For darker colors with an LRV less than 55: Paint must be vinyl-safe from a vinyl-safe color palette.
 - 4) For custom color, use a coating with solar reflective pigments

2.6 ACCESSORY PRODUCTS

A. Fasteners:

1. AZEK® Cortex for Trim
2. Use fasteners design for wood trim and wood siding (thinner shank, blunt point, full round head) with AZEK®.
3. Use a highly durable fastener such as stainless steel or hot-dipped galvanized.
4. Staples, small brads and wire nails must not be used as fastening members.
5. The fasteners should be long enough to penetrate the solid wood substrate a minimum of 1 1/2".
6. Standard nail guns work well with AZEK® trim products.
7. Use 2 fasteners per every framing member for trimboard applications. Trimboards 12" or wider, as well as sheets, will require additional fasteners.
8. Fasteners must be installed no more than 2" from the end of each board.
9. AZEK® should be fastened into a flat, solid substrate. Fastening AZEK® into hollow or uneven areas must be avoided.
10. Pre-drilling is typically not required unless a large fastener is used or product is installed in low temperatures.
11. 3/8" and 1/2" sheet product is not intended to be ripped into trim pieces. These profiles must be glued to a substrate and mechanically fastened.

B. Adhesives:

1. Glue all AZEK® to AZEK® joints such as window surrounds, long fascia runs, etc. with AZEK® Adhesive, a cellular pvc cement, to prevent joint separation.
2. The glue joint should be secured with a fastener and/or fastened on each side of the joint to allow adequate bonding time.
3. AZEK® Adhesive has a working time of 10 minutes and will be fully cured in 24 hours.
4. If standard pvc cements are used, keep in mind these products typically cure quickly which will result in limited working time and may reduce adhesive strength.
5. Surfaces to be glued should be smooth, clean and in complete contact with each other.
6. To bond AZEK® to other substrates, various adhesives may be used. Consult adhesive manufacturer to determine suitability.

C. Sealants:

1. Use urethane, polyurethane or acrylic based sealants without silicone.

2.7 FINISHES

A. AZEK products do not require paint for protection but may be painted to achieve a custom color.

B. Preparation:

1. No special surface preparations are required prior to painting - sanding is not necessary for paint adhesion.
2. Surface must be clean and dry.
3. Use a 100% acrylic latex paint with a Light Reflective Value (LRV) of 55 or higher.
4. Follow the paint manufacturer's recommendations to apply.

PART III EXECUTION

3.01 INSTALLATION

A. Manufacturer instructions:

1. Comply with manufacturer's product catalog installation instructions and product technical bulletin instructions.

B. Cutting:

1. AZEK® products can be cut using the same tools used to cut lumber.
2. Carbide tipped blades designed to cut wood work well. Avoid fine tooth metal cutting blades.
3. Rough edges from cutting may be caused by excessive friction, poor board support, or worn or improper tooling.

C. Cutting:

1. AZEK® products can be drilled using the same tools used to drill lumber.
2. Drilling AZEK® products is similar to drilling a hardwood. Care should be taken to avoid frictional heat build-up.
3. Use standard woodworking drills. Do not use drills made for normal rigid pvc.
4. Periodic removal of AZEK® shavings from the drill hole may be necessary.

D. Milling:

1. AZEK® products can be milled using standard milling machines used to mill lumber.
2. Relief Angle 20° to 30°
3. Cutting speed to be optimized with the number of knives and feed rate.

E. Routing:

1. AZEK® products can be routed using standard router bits and the same tools used to rout lumber.
2. Carbide tipped router bits are recommended.

F. Edge Finishing:

1. Edges can be finished by sanding, grinding or filing with traditional woodworking tools.

G. Nail Location:

1. Use 2 fasteners per every framing member for trimboard applications.
2. Trimboards over 12" or wider, as well as sheets, will require additional fasteners.
3. Fasteners must be installed no more than 2" from the end of each board.

H. Thermal Expansion and Contraction:

1. AZEK® products expand and contract with changes in temperature.
2. Properly fastening AZEK® material along its entire length will minimize expansion and contraction.
3. When properly fastened, allow 1/8" per 18 foot of AZEK® product for expansion and contraction.
4. Joints between pieces of AZEK® should be glued to eliminate joint separation. When gaps are glued on a long run of AZEK®, allow expansion and contraction at ends of the run.

END OF SECTION



Specs and Installation Tips

(See Tuftex Installation Guide for more information.)

Specifications

- Panel Width:** 26" U.S. Standard
- Corrugation Height:** 9/16"
- Panel Length:** 8', 10', 12' Standard and 14', 16' available in some colors/
profiles by special order
- Aluminum Nails:** 1 3/4" with washers, 100 per box, 24 boxes per case
- Nails per panel:** 8' = 25 nails 10' = 30 nails 12' = 35 nails
- Closures:** Foam Closures = 3' length (pack of 5)
Wood Closures = 6' length (minimum order of 24)
Round profile for SeaCoaster
Square profile for UltraVinyl & PolyCarb
- Light Transmission:** SeaCoaster Translucent Clear--75%
SeaCoaster Translucent White--70%
UltraVinyl Grow Clear--93%
PolyCarb Clear--93%
PolyCarb Translucent White--78%
PolyCarb Smoke--84%
- Load Bearing Capacity on 24" Centers:**
SeaCoaster = 90 lbs./sq. ft.
UltraVinyl = 90 lbs./sq. ft.
PolyCarb = 115 lbs./sq. ft.

Panels Packaged in Bundles of 10

Freight Prepaid on Orders of 100 Panels

To Remove Panel Labels: Use either mild detergent or mild citrus-based cleaner.



Specs and Installation Tips

(See Tuftex Installation Guide for more information.)

Installation Tips

- Storage:** Do not stack Tuftex in direct sunlight or in an enclosure subject to very high temperatures. Vertical storage indoors is preferred.
- Cutting:** Cut single panels with a pair of snips or heavy duty scissors. Multiple panels can be cut with a circular saw (plywood blade reversed) or a fine tooth hand saw.
- Side and End Laps:** Seal all side and end laps with a silicone sealer. Overlap sides of panel one corrugation and overlap ends a maximum of 4".
- Pitch:** Plan a minimum of 1" pitch per foot of run. In heavy snow areas, plan up to 3" pitch per foot. Greater pitch = less likelihood of leaks.
- Crossbrace Support Structure:** Install Tuftex Vinyl panels on a maximum of 24" on center. Tuftex PolyCarb can span 36" on center.
- Heat and Temperature Issues:** Choose the right product for your project. For projects in high heat or cold areas where the surface temperature ranges from +270°F to -40°F select Tuftex PolyCarb. Vinyl Opaque panels are suitable for all weather conditions and surface temperatures up to 150°F. Vinyl Translucent and Clear panels are to be installed for use in milder weather conditions only, and are not recommended for locations with high UV or surface temperatures that can exceed 125°F. Never install Tuftex panels directly over dark colored rafters or closure strips. For best results, paint (white) the top edge of the rafter or closure strip that is exposed to sunlight. Do not overlap or apply over existing roofing or lattice.
- Ventilation:** All Tuftex covered structures need adequate ventilation to control condensation and ensure coolness. If high heat may develop choose Tuftex PolyCarb panels for your project.
- Nailing:** Important - Pre-drill all fastening holes. Always pre-drill holes prior to fastening panels. The diameter of the hole must be 2/16 to 3/16 larger than the diameter of the shaft of the fastener. Do not over-tighten fasteners.

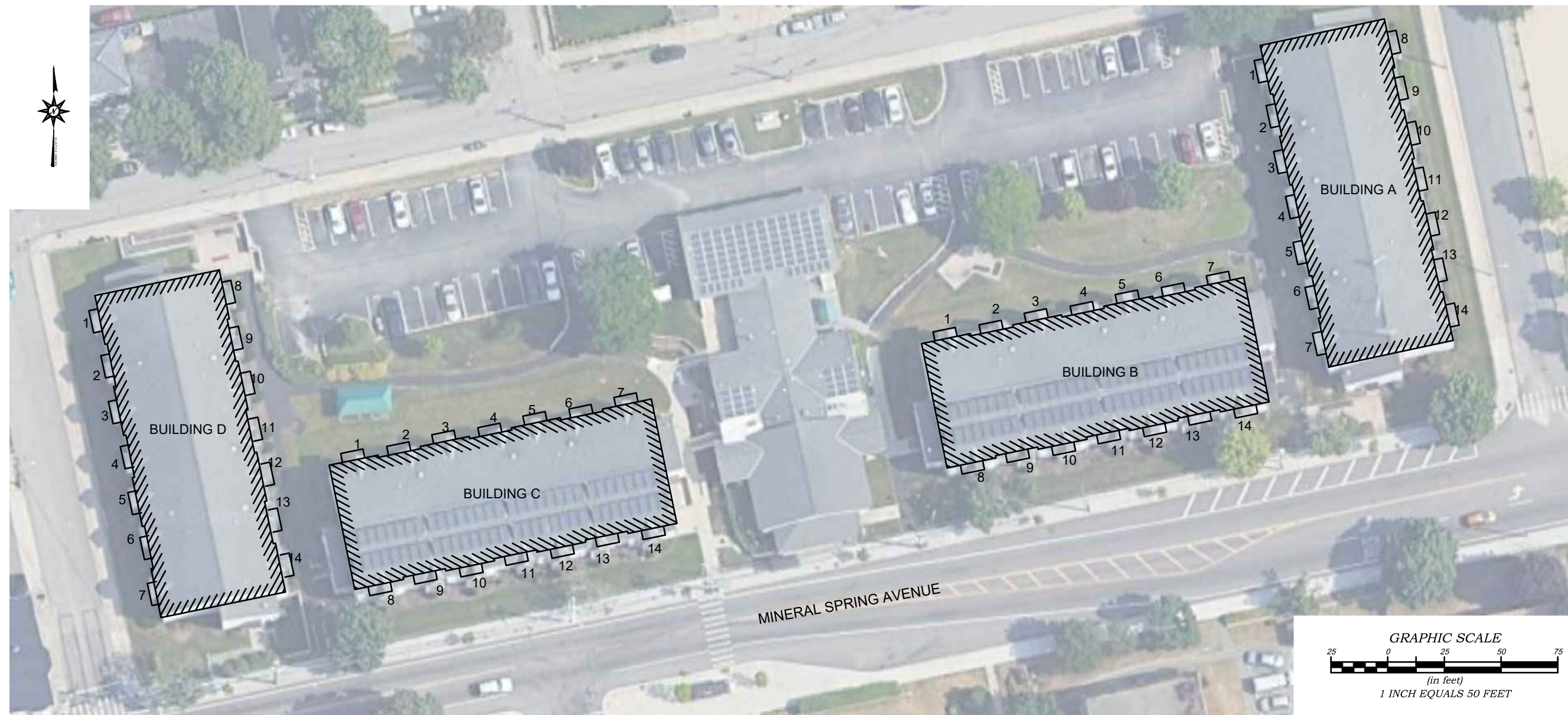

ST. GERMAIN DECK REPLACEMENT	
BUILDING	NO. OF DECKS
A	14
B	14
C	14
D	14
TOTAL	56

SCOPE OF WORK:

1. REMOVE EXISTING ALUMINUM RAILINGS TO ALLOW FOR PROPOSED WORK. AT THE CONCLUSION OF WORK, CUT TO FIT AND REINSTALL RAILING.
2. REMOVE & REPLACE EXISTING CANOPY FASCIA WITH NEW WHITE 1"x6" AZEK TRIM OR APPROVED EQUAL.
3. REMOVE & REPLACE EXISTING TRIM AGAINST BUILDING WITH NEW WHITE 1"x6" AZEK TRIM OR APPROVED EQUAL.
4. WRAP EXISTING 2x8" DECK FRAMING WITH NEW WHITE 1"x8" AZEK TRIM OR APPROVED EQUAL.
5. FURNISH & INSTALL NEW TUFTEX VINYL CORRUGATED SHEETING OR APPROVED EQUAL UNDER DECK FRAMING (SECOND FLOOR).

ALTERNATE BID ITEM:

WRAP EXISTING 6"x6" POSTS WITH NEW WHITE 1"x6" AZEK TRIM OR APPROVED EQUAL.



TYPICAL EXTERIOR BLDG DECK



TYPICAL EXTERIOR BLDG VIEW



TYPICAL TWO FLOOR DECK

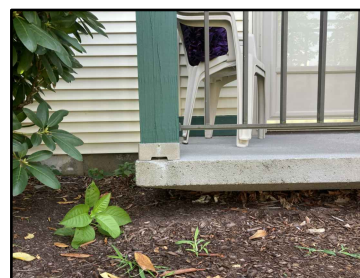

TYPICAL FIRST FLOOR CONCRETE DECK

NOTE:
 1. AERIAL IMAGERY OBTAINED FROM GOOGLE EARTH.
 2. BUILDING SITE INFORMATION OBTAINED FROM PAWTUCKET TAX ASSESSOR DATABASE AND FIELD SITE INVESTIGATION SERVICES COMPLETED BY ES&M PERSONNEL ON JULY 26, 2021.

NO	DESCRIPTION	DATE	AUTHOR

ES&M
 Pawtucket, RI 02860
 Narragansett, MA 02882-8000
 Newburyport, MA 01754-0363
 www.esm-inc.com

PREPARED FOR:
 PAWTUCKET HOUSING AUTHORITY
 ST. GERMAIN MANOR
 401 MINERAL SPRING AVENUE
 PAWTUCKET, RI 02860

CONTRACT/BID DOCUMENTS

SHEET TITLE:
 SITE LAYOUT
 ST. GERMAIN MANOR
 DECK IMPROVEMENTS

Project No.: 7180-22
Designed By: EMD
Drawn By: EMD
Checked By: RGM
Date: AUGUST 2021
Scale: AS SHOWN

- TRIM:** AZEK TRIM OR APPROVED EQUAL (WHITE) INSTALLED IN ACCORDANCE WITH THE MANUFACTURER'S SPECIFICATIONS.
- DECK SHEETING:** TUFTEX VINYL CORRUGATED SHEETING OR APPROVED EQUAL.
- SUBMITTALS:** THE CONTRACTOR SHALL SUBMIT A SAMPLE & SPECIFICATION OF THE FOLLOWING ITEMS FOR REVIEW AND APPROVAL BEFORE ORDERING ANY MATERIAL:

- TRIM SPECIFICATION SHEET FOR 6"x6" POST and 2"x8" DECK FRAMING;
- RAILING SPECIFICATIONS
- VINYL CORRUGATED SPECIFICATIONS

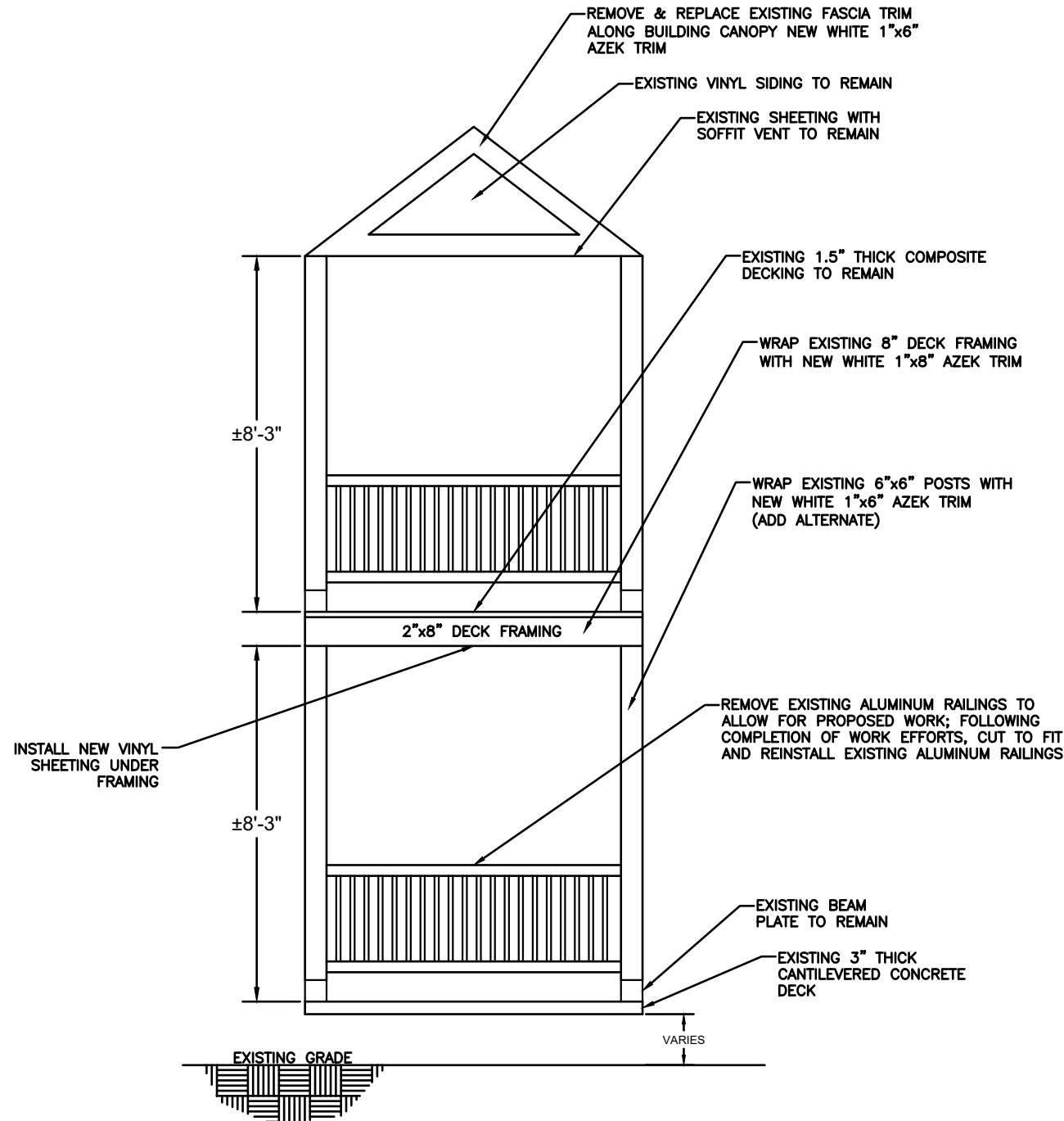

TYPICAL DECK ELEVATION VIEW DETAIL
NOT TO SCALE

NOTE:
1. CONTRACTOR TO VERIFY DIMENSIONS IN FIELD PRIOR TO ORDERING ANY MATERIAL.

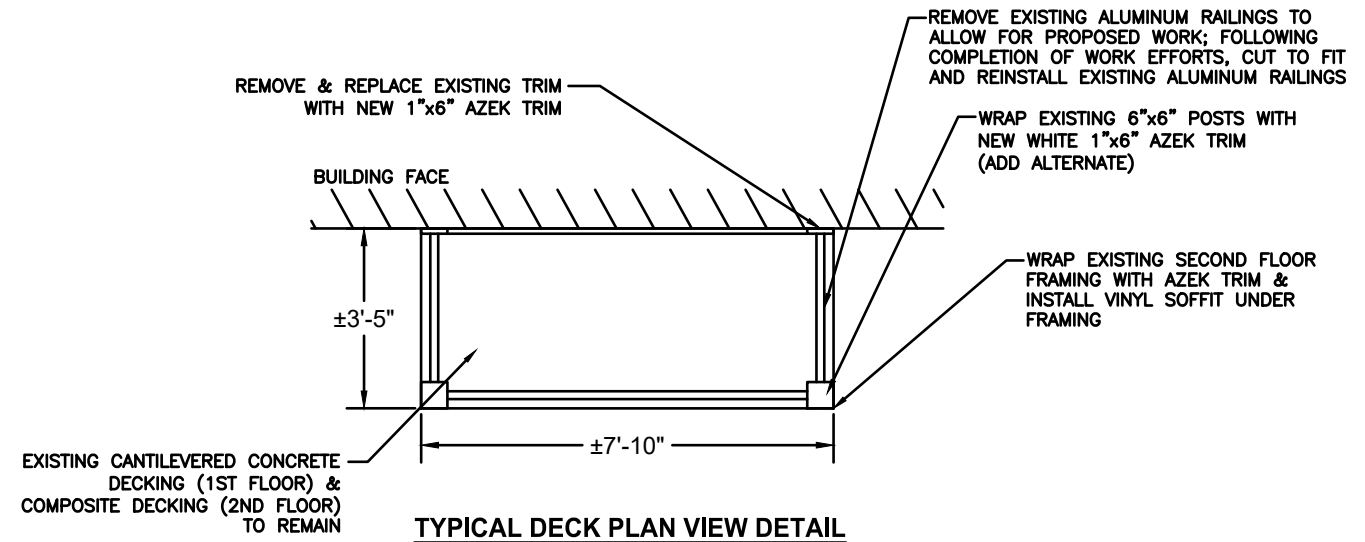

TYPICAL DECK PLAN VIEW DETAIL
NOT TO SCALE

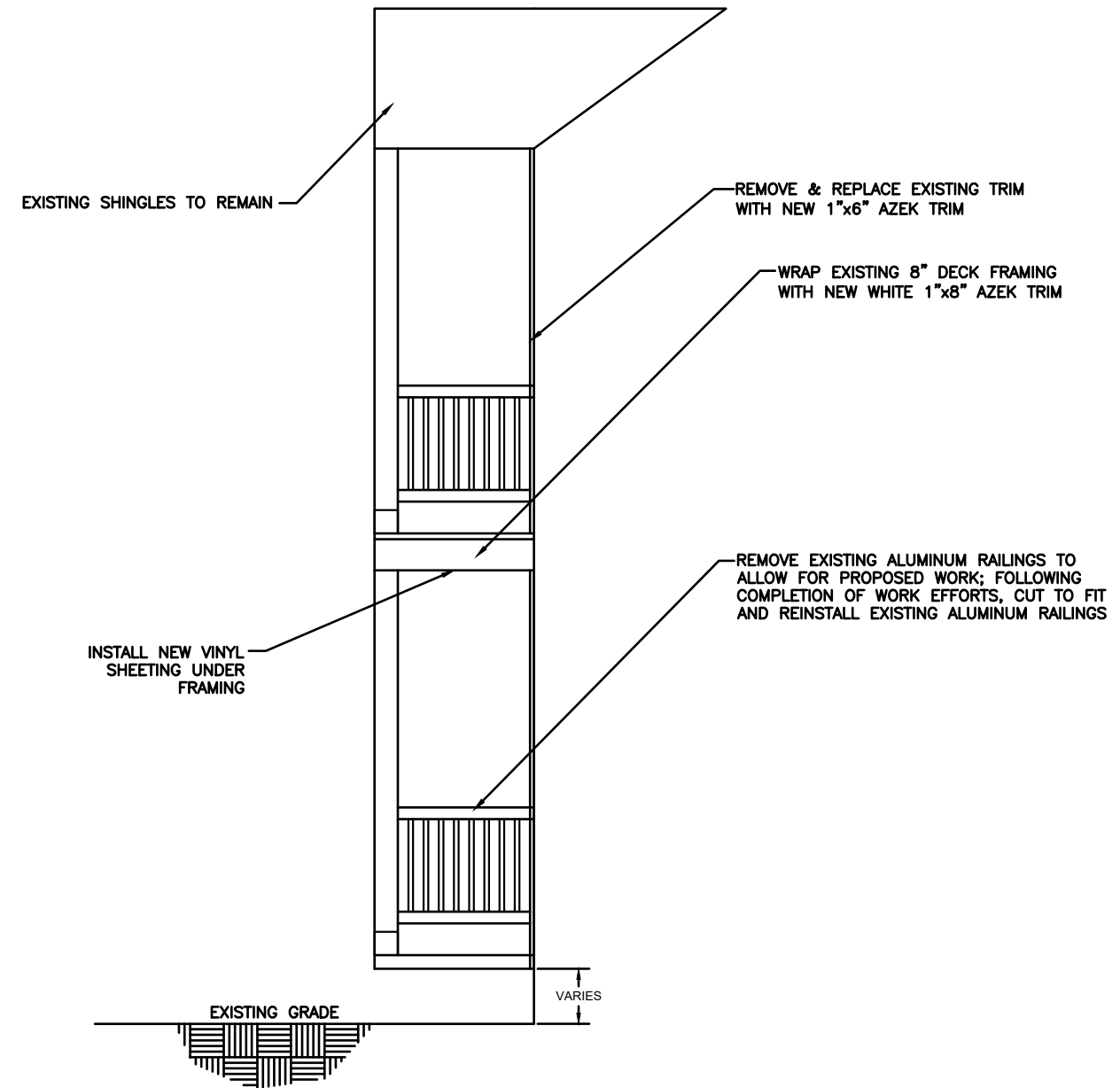

TYPICAL DECK SECTION VIEW DETAIL
NOT TO SCALE

NO.	DESCRIPTION	DATE	AUTHOR

ES&M
Pawtucket, RI 401-726-6860
Norton, MA 508-226-1800
Newburyport, MA 617-840-0363
www.esm-inc.com

PREPARED FOR:
PAWTUCKET HOUSING AUTHORITY
ST. GERMAIN MANOR
401 MINERAL SPRING AVENUE
PAWTUCKET, RI 02860

CONTRACT/BID DOCUMENTS

SECRET TITLE:
DETAILS & NOTES
ST. GERMAIN MANOR
DECK IMPROVEMENTS

Project No.: 7180-22
Designed By: EMD
Drawn By: EMD
Checked By: RGM
Date: AUGUST 2021
Scale: AS SHOWN